

8.2 APPLICATION CIRCUIT

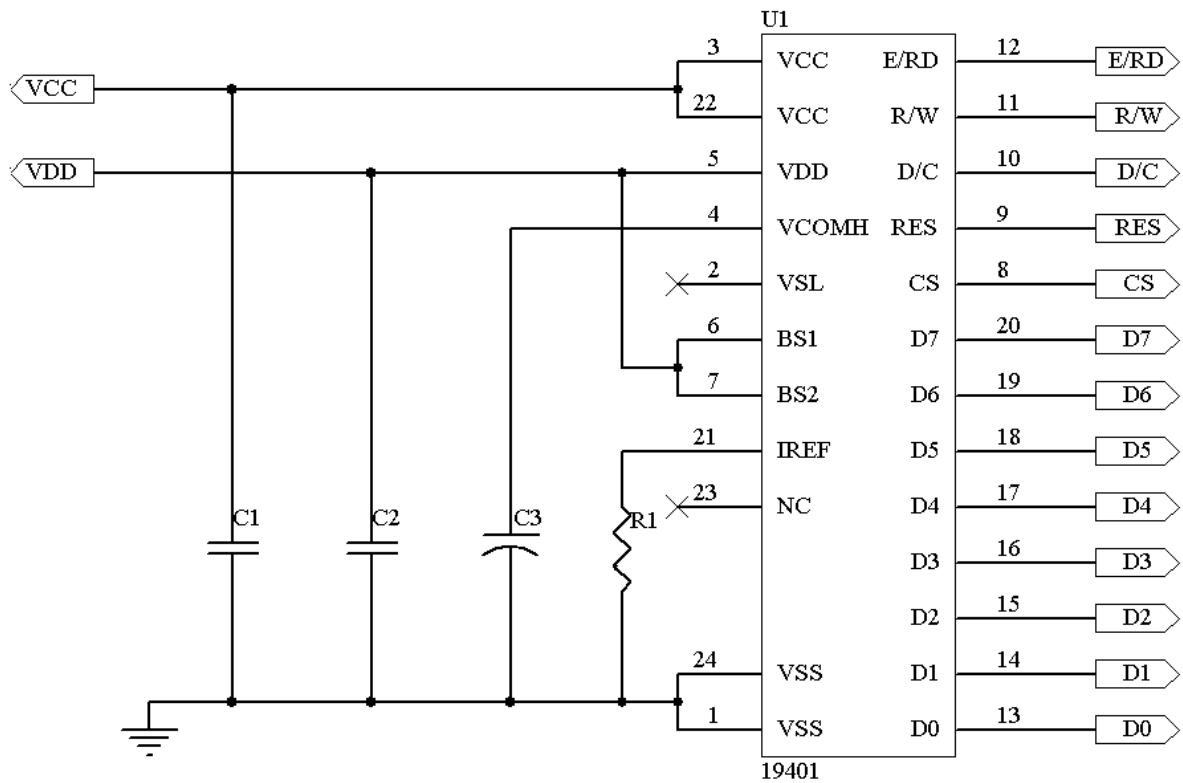

Recommend components:

C1: 2.2uF/25V (0805)

C2: 1uF/16V (0603)

C3: 4.7uF/25V (TANTALUM or Solid Tantalum 4.7uF/ 25V/ A Case (Vishay 572D))

R1: 1M ohm/1% (0603)

Notes: This circuit is for 8080 interface.

8.3 COMMAND TABLE

Refer to SSD1325 IC Spec.
