

CiA Draft Standard 401



Device profile for generic I/O modules

Version: 3.0

03 June 2008

© CAN in Automation (CiA) e. V.

HISTORY

Date	Changes
2002-05-17	<i>Publication of version 2.1 as draft standard</i>
2006-10-02	<i>Publication of version 3.0 as draft standard proposal</i> <ul style="list-style-type: none">- Editorial and lay-out changes have been made- Object 1000_n: Additional definitions- Detailed definitions of PDO parameters have been included- Additional PDO mapping for joystick devices- Warning if analogue input global interrupt is disabled- Additional dead-band objects for joystick devices
2008-06-03	<i>Publication of version 3.0 as draft standard</i>

General information on licensing and patents

CAN in AUTOMATION (CiA) calls attention to the possibility that some of the elements of this CiA specification may be subject of patent rights. CiA shall not be responsible for identifying any or all such patent rights.

Because this specification is licensed free of charge, there is no warranty for this specification, to the extent permitted by applicable law. Except when otherwise stated in writing the copyright holder and/or other parties provide this specification “as is” without warranty of any kind, either expressed or implied, including, but not limited to, the implied warranties of merchantability and fitness for a particular purpose. The entire risk as to the correctness and completeness of the specification is with you. Should this specification prove failures, you assume the cost of all necessary servicing, repair or correction.

Trademarks

CANopen® and CiA® are registered community trademarks of CAN in Automation. The use is restricted for CiA members or owners of CANopen vendor ID. More detailed terms for the use are available from CiA.

© CiA 2008

All rights reserved. Unless otherwise specified, no part of this publication may be reproduced or utilized in any form or by any means, electronic or mechanical, including photocopying and microfilm, without permission in writing from CiA at the address below.

CAN in Automation e. V.
Kontumazgarten 3
DE - 90429 Nuremberg, Germany
Tel.: +49-911-928819-0
Fax: +49-911-928819-79
Url: www.can-cia.org
Email: headquarters@can-cia.org

CONTENTS

1	Scope	7
2	Normative references.....	7
3	Definitions and abbreviations	7
3.1	Definition	7
3.2	Abbreviations.....	7
4	Operating principle.....	7
4.1	Introduction	7
4.2	Node-ID assignment	8
5	Error handling	8
5.1	Principle	8
5.2	Error behavior.....	8
5.3	Analogue input disable warning	8
5.4	Additional error code definitions	8
6	Pre-definitions.....	9
6.1	Introduction	9
6.2	Pre-defined communication objects	9
6.2.1	Object 1000 _h : Device type	9
6.2.2	Object 1001 _h : Error register	10
6.2.3	Object 1029 _h : Error behavior.....	10
6.2.4	RPDO 1 (digital outputs).....	11
6.2.5	TPDO 1 (digital inputs)	13
6.2.6	RPDO 2 (analogue outputs).....	15
6.2.7	TPDO 2 (analogue inputs)	17
6.2.8	RPDO 3 (additional analogue outputs).....	19
6.2.9	TPDO 3 (additional analogue inputs)	22
6.2.10	RPDO 4 (additional analogue outputs).....	24
6.2.11	TPDO 4 (additional analogue inputs)	26
6.2.12	Manufacturer-specific PDOs	29
7	Object dictionary	29
7.1	Introduction	29
7.2	Input and output function principles	29
7.2.1	Object dictionary for the digital input and output modules	29
7.2.2	Digital input module	30
7.2.3	Digital output module.....	31
7.2.4	Analogue input module	31
7.2.5	Analogue output module	32
8	Detailed object definitions	33
8.1	Introduction	33
8.2	Digital input module.....	33
8.2.1	Object 6000 _h : Read input 8-bit.....	33
8.2.2	Object 6002 _h : Polarity input 8-bit	35
8.2.3	Object 6003 _h : Filter constant input 8-bit.....	36
8.2.4	Object 6005 _h : Global interrupt enable digital 8-bit.....	37
8.2.5	Object 6006 _h : Interrupt mask any change 8-bit.....	38
8.2.6	Object 6007 _h : Interrupt mask low-to-high 8-bit	39
8.2.7	Object 6008 _h : Interrupt mask high-to-low 8-bit	40

8.2.8	Object 6020 _h to 6027 _h : Read input bit 1 to 128 to read input bit 897 to 1024	41
8.2.9	Object 6030 _h to 6037 _h : Polarity input bit 1 to 128 to polarity input bit 897 to 1024	43
8.2.10	Object 6038 _h to 603F _h : Filter constant input bit 1 to 128 to filter constant input bit 897 to 1024	44
8.2.11	Object 6050 _h to 6057 _h : Interrupt mask input bit any change 1 to 128 to interrupt mask input bit any change 897 to 1024	45
8.2.12	Object 6060 _h to 6067 _h : Interrupt mask input low-to-high bit 1 to 128 to interrupt mask input low-to-high bit 897 to 1024	46
8.2.13	Object 6070 _h to 6077 _h : Interrupt mask input high-to-low bit 1 to 128 to interrupt mask input high-to-low bit 897 to 1024	47
8.2.14	Object 6100 _h : Read input 16-bit	49
8.2.15	Object 6102 _h : Polarity input 16-bit	50
8.2.16	Object 6103 _h : Filter constant input 16-bit	51
8.2.17	Object 6106 _h : Interrupt mask input any change 16-bit	52
8.2.18	Object 6107 _h : Interrupt mask input low-to-high 16-bit	53
8.2.19	Object 6108 _h : Interrupt mask input high-to-low 16-bit	55
8.2.20	Object 6120 _h : Read input 32-bit	56
8.2.21	Object 6122 _h : Polarity input 32-bit	57
8.2.22	Object 6123 _h : Filter constant input 32-bit	58
8.2.23	Object 6126 _h : Interrupt mask input any change 32-bit	59
8.2.24	Object 6127 _h : Interrupt mask input low-to-high 32-bit	61
8.2.25	Object 6128 _h : Interrupt mask input high-to-low 32-bit	62
8.3	Digital output module	63
8.3.1	Object 6200 _h : Write output 8-bit	63
8.3.2	Object 6202 _h : Change polarity output 8-bit	64
8.3.3	Object 6206 _h : Error mode output 8-bit	66
8.3.4	Object 6207 _h : Error value output 8-bit	67
8.3.5	Object 6208 _h : Filter mask output 8-bit	68
8.3.6	Object 6220 _h to 6227 _h : Write output bit 1 to 128 to write output bit 897 to 1024	69
8.3.7	Object 6240 _h to 6247 _h : Change polarity output bit 1 to 128 to change polarity output bit 897 to 1024	70
8.3.8	Object 6250 _h to 6257 _h : Error mode output lines 1 to 128 to error mode output lines 897 to 1024	71
8.3.9	Object 6260 _h to 6267 _h : Error value output bit 1 to 128 to error value output bit 897 to 1024	73
8.3.10	Object 6270 _h to 6277 _h : Filter mask output bit 1 to 128 to filter mask output bit 897 to 1024	74
8.3.11	Object 6300 _h : Write output 16-bit	75
8.3.12	Object 6302 _h : Change polarity output 16-bit	76
8.3.13	Object 6306 _h : Error mode output 16-bit	78
8.3.14	Object 6307 _h : Error value output 16-bit	79
8.3.15	Object 6308 _h : Filter mask output 16-bit	80
8.3.16	Object 6320 _h : Write output 32-bit	81
8.3.17	Object 6322 _h : Change polarity output 32-bit	82
8.3.18	Object 6326 _h : Error mode output 32-bit	84
8.3.19	Object 6327 _h : Error value output 32-bit	85
8.3.20	Object 6328 _h : Filter mask output 32-bit	86
8.4	Analogue input module	87

8.4.1	Object 6400 _h : Read analogue input 8-bit.....	87
8.4.2	Object 6401 _h : Read analogue input 16-bit.....	88
8.4.3	Object 6402 _h : Read analogue input 32-bit.....	90
8.4.4	Object 6403 _h : Read analogue input float.....	91
8.4.5	Object 6404 _h : Read manufacturer-specific analogue input	92
8.5	Analogue output module	94
8.5.1	Object 6410 _h : Write analogue output 8-bit.....	94
8.5.2	Object 6411 _h : Write analogue output 16-bit.....	95
8.5.3	Object 6412 _h : Write analogue output 32-bit.....	96
8.5.4	Object 6413 _h : Write analogue output float.....	97
8.5.5	Object 6414 _h : Write manufacturer-specific analogue output	99
8.6	Analogue input set-ups	100
8.6.1	Object 6420 _h	100
8.6.2	Object 6421 _h : Analogue input interrupt trigger selection.....	100
8.6.3	Object 6422 _h : Analogue input interrupt source	101
8.6.4	Object 6423 _h : Analogue input global interrupt enable.....	103
8.6.5	Object 6424 _h : Analogue input interrupt upper limit integer.....	103
8.6.6	Object 6425 _h : Analogue input interrupt lower limit integer	104
8.6.7	Object 6426 _h : Analogue input interrupt delta unsigned.....	106
8.6.8	Object 6427 _h : Analogue input interrupt negative delta unsigned.....	107
8.6.9	Object 6428 _h : Analogue input interrupt positive delta unsigned.....	108
8.6.10	Object 6429 _h : Analogue input interrupt upper limit float	109
8.6.11	Object 642A _h : Analogue input interrupt lower limit float.....	110
8.6.12	Object 642B _h : Analogue input interrupt delta float.....	112
8.6.13	Object 642C _h : Analogue input interrupt negative delta float	113
8.6.14	Object 642D _h : Analogue input interrupt positive delta float.....	114
8.6.15	Object 642E _h : Analogue input offset float.....	115
8.6.16	Object 642F _h : Analogue input pre-scaling float	116
8.6.17	Object 6430 _h : Analogue input SI unit	118
8.6.18	Object 6431 _h : Analogue input offset integer	119
8.6.19	Object 6432 _h : Analogue input pre-scaling integer	120
8.7	Analogue output set-ups	121
8.7.1	Object 6440 _h	121
8.7.2	Object 6441 _h : Analogue output offset float	121
8.7.3	Object 6442 _h : Analogue output scaling float.....	123
8.7.4	Object 6443 _h : Analogue output error mode	124
8.7.5	Object 6444 _h : Analogue output error value integer.....	125
8.7.8	Object 6445 _h : Analogue output error value float.....	126
8.7.9	Object 6446 _h : Analogue output offset integer	128
8.7.10	Object 6447 _h : Analogue output scaling integer.....	129
8.7.11	Object 6450 _h : Analogue output SI unit	130
8.8	General device profile objects.....	131
8.8.1	Object 67FF _h : Device type	131
Annex A	: Joystick	132
A.1	Scope.....	132
A.2	Pre-defined communication objects for joysticks.....	132
A.2.1	Object 1000 _h : Device type	132
A.3	Joystick buttons.....	132

A.4 Joystick proportional inputs	132
A.5 Joystick PDO mappings.....	132
A.5.1 Introduction	132
A.5.2 1st TPDO mapping (buttons)	133
A.5.3 2nd TPDO mapping (proportional inputs).....	133
A.5.4 Specific PDO mapping for 3-D joysticks	133
A.5.5 Specific PDO mapping for 2-D joysticks	133
A.6 Joystick signal conditioning	134
A.6.1 Introduction	134
A.6.2 Object 6460 _n : Analogue input dead-band unsigned	134
A.6.3 Object 6461 _n : Analogue input dead-band float.....	135
A.6.4 Object 6462 _n : Analogue input post-scaling unsigned	136
A.6.5 Object 6463 _n : Analogue input post-scaling float.....	138
A.7 Joystick implementation hints	139
A.7.1 Periodical PDO transmission	139
A.7.2 Additional proportional inputs	139
A.7.3 Transmission of proportional inputs.....	139

1 Scope

This specification represents the CANopen device profile for generic digital and analogue input and output modules. Devices compliant to this specification use communication techniques, which conform to those described in the CANopen application layer and communication profile specification. In addition, programmable I/O devices may use communication techniques, which conform to those described in the CANopen additional application layer functions.

In the appendices, some specific I/O devices are defined.

2 Normative references

/CiA301/	CiA 301, CANopen application layer and communication profile
/CiA303-2/	CiA 303-2, CANopen additional specification – Part 2: Representation of SI units and prefixes
/CiA305/	CiA 305, CANopen layer setting services

3 Definitions and abbreviations

3.1 Definition

The definitions given in /CiA301/ and /CiA303-2/ apply for this specification, too.

3.2 Abbreviations

CAN	Controller area network
CAN-ID	CAN identifier
COB	Communication object
COB-ID	COB identifier
I/O	Input and output
PDO	Process data object
RPDO	Receive process data object
SDO	Service data object
TPDO	Transmit process data object

4 Operating principle

4.1 Introduction

The purpose of I/O modules is to connect sensors and actuators to CANopen networks. In NMT operational mode, input data are transmitted from the inputs via TPDOs. By default, the PDO transmission is triggered by an interrupt (event). Optionally PDOs are transmitted synchronously or remotely requested. In addition, it is possible to read input data via SDO communication from another module, or to write data via SDO to the network, if the module provides SDO client functionality.

Output data can be received via RPDO by those I/O modules that have output capabilities. Output data also can be received via SDO communication services.

However, the main purpose of SDO communication is to configure an I/O module. The module can receive via SDO I/O configuration data, parameters for converting data into meaningful measurements and so on. I/O modules compliant with this device profile use pre-defined

PDOs. The default mapping of application objects into TPDO respectively RPDO is changeable via SDO, if variable PDO mapping is supported. An I/O module provides optionally sync producer/consumer, time-stamp producer/consumer and emergency producer/consumer functionality. For new designs, it is recommended to support Heartbeat functionality.

4.2 Node-ID assignment

The node-ID assignment is manufacturer specific. If a node-ID assignment via CAN network is required (e.g. for IP 67-rated devices), it is recommended to use the layer setting protocols as defined in /CiA305/.

5 Error handling

5.1 Principle

Emergency messages are triggered by internal errors in the device and they are assigned the highest possible priority to ensure that they get access to the bus without latency. By default, the Emergency messages contain the error field with pre-defined error numbers and additional information.

5.2 Error behavior

If a serious device failure is detected the module shall enter by default autonomously the Pre-operational state. If 1029_h object is implemented, the device may be configured to enter alternatively the Stopped state or remain in the current state in case of a device failure. Device failures should include the following communication errors:

- Bus-off conditions of the CAN interface
- Life guarding event with the state 'occurred'
- Heartbeat event with state 'occurred'

Severe device errors also may be caused by device internal failures.

5.3 Analogue input disable warning

If the CANopen device transits to NMT operational state and the Analogue input global interrupt object (6423_h) is set to FALSE, it shall transmit an Emergency message with the error code 0080_h. This Emergency message shall not cause a transition into NMT pre-operational or NMT stopped state.

5.4 Additional error code definitions

Error code definitions used by this profile are given in Table 1.

Table 1 — Error code definition

Error code	Definition
0080 _h	Warning: Analogue inputs disabled
2310 _h	Current at outputs too high (overload)
2320 _h	Short circuit at outputs
2330 _h	Load dump at outputs
3110 _h	Input voltage too high
3120 _h	Input voltage too low
3210 _h	Internal voltage too high

Error code	Definition
3220 _h	Internal voltage too low
3310 _h	Output voltage too high
3320 _h	Output voltage too low

6 Pre-definitions

6.1 Introduction

If a device supports a specific type of I/O functionality (analogue/digital I/O) it shall support the related default PDOs. However, the module may support additional manufacturer-specific PDOs. If variable PDO mapping is supported the PDO default settings may be changed by means of configuration.

There may be implemented up to 4 enabled TPDOs and up to 4 enabled RPDOs with default mappings. If a module does not support a specific I/O function, the related default PDOs shall remain unused. If a device supports more than the pre-mapped digital input or output channels, the analogue default PDOs shall not be used to map digital inputs or outputs by default. The additional digital I/Os may use additional PDOs. This shall correspond to additional analogue channels.

All TPDOs with transmission type 255 shall be transmitted when entering the operational state.

6.2 Pre-defined communication objects

Devices compliant with this specification come with default values for some communication objects (1000_h to 1FFF_h), which are not specified in all details in /CiA301/.

6.2.1 Object 1000_h: Device type

This object describes the type of device and its functionality. For multiple device modules the *additional information* field shall contain FFFF_h. In this case, the 67FF_h object shall be implemented. Figure 1 shows the value structure as defined in /CiA301/ and defines the *additional information* field. Table 2 defines the values for the fields *I/O functionality* and *M*. The pre-defined, generic PDO mapping is described in this specification, the device-specific PDO mapping is not in the scope of this specification.

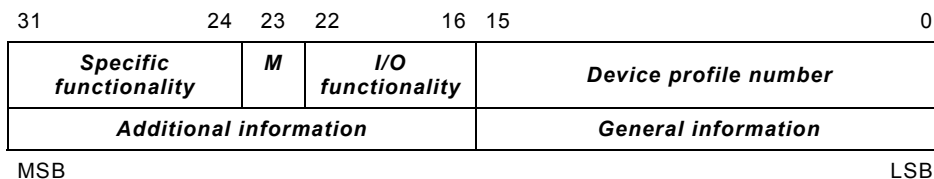

Figure 1 — Value structure

Table 2 — Value definition for *I/O functionality* and *M*

Field name	Definition
Device profile number	401 _d
I/O functionality – Bit 16	1 _b = digital input(s) implemented 0 _b = not implemented
I/O functionality – Bit 17	1 _b = digital output(s) implemented 0 _b = not implemented
I/O functionality – Bit 18	1 _b = analogue input(s) implemented 0 _b = not implemented
I/O functionality – Bit 19	1 _b = analogue output(s) implemented 0 _b = not implemented

Field name	Definition
I/O functionality – Bit 20 to Bit 22	Reserved
M(apping of PDOs)	1 _b = Device-specific PDO mapping is supported 0 _b = Pre-defined, generic PDO mapping is supported (see 6.2.4 to 6.2.11)
NOTE Any combination of digital/analogue, inputs and outputs is allowed; one of the bits 16 to 19 shall be 1 _b .	

Table 3 defines the values of the specific functionality sub-field.

Table 3 — Value definition for the specific functionality

Code	Function	Reference
00 _h	No specific function	-
01 _h	Joystick	Appendix A
02 _h	Joystick	Appendix A
03 _h	Joystick	Appendix A
04 _h to FF _h	Reserved	-

6.2.2 Object 1001_h: Error register

The device-specific bit in the status byte is reserved for future use.

6.2.3 Object 1029_h: Error behavior

The object specifies to which state an I/O module shall be set, when a communication error, output error or input error is detected. The following values are defined, all others are reserved:

00_h = transit to NMT pre-operational (only if the current NMT state is operational) state

01_h = remain in current NMT state

02_h = transit to NMT stopped state

In addition to the specification in /CiA301/ the following sub-indices may be implemented.

Table 4 specifies the entry description.

Table 4 — Entry description

Attribute	Value
Sub-Index	02 _h
Description	Output error
Access	rw
Entry category	Optional
PDO mapping	No
Value range	00 _h to 02 _h
Default value	00 _h

Sub-Index	03 _h
Description	Input error
Access	rw
Entry category	Optional
PDO mapping	No
Value range	00 _h to 02 _h
Default value	00 _h

NOTE If the object 1029_h is not implemented, the device behaves in case of communication, input or output failures as defined by the default value.

6.2.4 RPDO 1 (digital outputs)

This RPDO receives the values of up to 64 digital outputs.

NOTE After power-on and application reset the values of the mapped outputs are as the default values or the stored values after configuration (stored values overwrites default values).

Table 5 defines the object description and Table 6 defines the entry description of the RPDO communication parameter.

Table 5 — Object description

Attribute	Value
INDEX	1400 _h
Name	RPDO 1 communication parameter
Object code	Record
Data type	PDO communication parameter record
Category	Conditional: Mandatory, if M-bit in object 1000 _h is set to 0 _b and bit 17 in object 1000 _h is set to 1 _b

Table 6 — Entry description

Attribute	Value
Sub-Index	00 _h
Description	Highest sub-index supported
Access	ro
Entry category	Mandatory
PDO mapping	No
Value range	02 _h
Default value	02 _h
Sub-Index	01 _h
Description	COB-ID
Access	rw
Entry category	Mandatory
PDO mapping	No
Value range	See /CiA301/
Default value	0000 0200 _h + node-ID

Sub-Index	02 _h
Description	Transmission type
Access	rw
Entry category	Mandatory
PDO mapping	No
Value range	See /CiA301/
Default value	255 _d

Table 7 defines the object description and Table 8 defines the entry description of the RPDO mapping parameter. The number of mapped objects into this RPDO depends on the hardware.

Table 7 — Object description

Attribute	Value
INDEX	1600 _h
Name	RPDO 1 mapping parameter
Object code	Record
Data type	PDO mapping parameter record
Category	Conditional: Mandatory, if 1400 _h is implemented

Table 8 — Entry description

Attribute	Value
Sub-Index	00 _h
Description	Highest sub-index supported
Access	rw
Entry category	Mandatory
PDO mapping	No
Value range	01 _h to 08 _h
Default value	01 _h to 08 _h
Sub-Index	01 _h
Description	1 st application object
Access	rw
Entry category	Mandatory
PDO mapping	No
Value range	See /CiA301/
Default value	6200 01 08 _h
Sub-Index	02 _h
Description	2 nd application object
Access	rw
Entry category	Conditional: Mandatory, if object 6200 02 _h is implemented
PDO mapping	No
Value range	See /CiA301/
Default value	6200 02 08 _h
to	

Sub-Index	08 _h
Description	8 th application object
Access	rw
Entry category	Conditional: Mandatory, if object 6200 08 _h is implemented
PDO mapping	No
Value range	See /CiA301/
Default value	6200 08 08 _h

6.2.5 TPDO 1 (digital inputs)

This TPDO transmits event-driven the values of maximum 64 digital inputs. If one digital input changes its value, this PDO shall be transmitted immediately. If an interrupt mask is enabled, the PDO shall be transmitted only if the interrupt condition is fulfilled.

Table 9 defines the object description and Table 10 defines the entry description of the TPDO communication parameter. The values are defined in /CiA301/. The sub-index 04_h is reserved for compatibility reasons and shall not be implemented.

Table 9 — Object description

Attribute	Value
INDEX	1800 _h
Name	TPDO 1 communication parameter
Object code	Record
Data type	PDO communication parameter record
Category	Conditional: Mandatory, if M-bit in object 1000 _h is set to 0 _b and bit 16 in object 1000 _h is set to 1 _b

Table 10 — Entry description

Attribute	Value
Sub-Index	00 _h
Description	Highest sub-index supported
Access	ro
Entry category	Mandatory
PDO mapping	No
Value range	02 _h to 05 _h
Default value	Manufacturer-specific
Sub-Index	01 _h
Description	COB-ID used by PDO
Access	rw
Entry category	Mandatory
PDO mapping	No
Value range	See /CiA301/
Default value	{0000 0180 _h , 4000 0180 _h } + node-ID

Sub-Index	02 _h
Description	Transmission type
Access	rw
Entry category	Mandatory
PDO mapping	No
Value range	See /CiA301/
Default value	255 _d
Sub-Index	03 _h
Description	Inhibit time
Access	rw
Entry category	Optional
PDO mapping	No
Value range	See /CiA301/
Default value	00 _h
Sub-Index	05 _h
Description	Event timer
Access	rw
Entry category	Optional
PDO mapping	No
Value range	See /CiA301/
Default value	00 _h

Table 11 defines the object description and Table 12 defines the entry description of the TPDO mapping parameter. The number of mapped objects into this TPDO depends on the hardware.

Table 11 — Object description

Attribute	Value
INDEX	1A00 _h
Name	TPDO 1 mapping parameter
Object code	Record
Data type	PDO mapping parameter record
Category	Conditional: Mandatory, if 1800 _h is implemented

Table 12 — Entry description

Attribute	Value
Sub-Index	00 _h
Description	Highest sub-index supported
Access	rw
Entry category	Mandatory
PDO mapping	No
Value range	01 _h to 08 _h
Default value	01 _h to 08 _h

Sub-Index	01 _h
Description	1 st application object
Access	rw
Entry category	Mandatory
PDO mapping	No
Value range	See /CiA301/
Default value	6000 01 08 _h
Sub-Index	02 _h
Description	2 nd application object
Access	rw
Entry category	Conditional: Mandatory, if object 6000 02 _h is implemented
PDO mapping	No
Value range	See /CiA301/
Default value	6000 02 08 _h
to	
Sub-Index	08 _h
Description	8 th application object
Access	rw
Entry category	Conditional: Mandatory, if object 6000 08 _h is implemented
PDO mapping	No
Value range	See /CiA301/
Default value	6000 08 08 _h

6.2.6 RPDO 2 (analogue outputs)

This RPDO receives asynchronously the 16-bit values of maximum 4 analogue outputs to the module. The default transmission type shall be 255.

NOTE After power-on and application reset the values of the mapped outputs are as the default values or the stored values after configuration (stored values overwrites default values).

Table 13 defines the object description and Table 14 defines the entry description of the RPDO communication parameter.

Table 13 — Object description

Attribute	Value
INDEX	1401 _h
Name	RPDO 2 communication parameter
Object code	Record
Data type	PDO communication parameter record
Category	Conditional: Mandatory, if M-bit in object 1000 _h is set to 0 _b and bit 19 in object 1000 _h is set to 1 _b

Table 14 — Entry description

Attribute	Value
-----------	-------

Device profile for generic I/O modules

Sub-Index	00 _h
Description	Highest sub-index supported
Access	ro
Entry category	Mandatory
PDO mapping	No
Value range	02 _h
Default value	02 _h
Sub-Index	01 _h
Description	COB-ID
Access	rw
Entry category	Mandatory
PDO mapping	No
Value range	See /CiA301/
Default value	0000 0300 _h + node-ID
Sub-Index	02 _h
Description	Transmission type
Access	rw
Entry category	Mandatory
PDO mapping	No
Value range	See /CiA301/
Default value	255 _d

Table 15 defines the object description and Table 16 defines the entry description of the RPDO mapping parameter. The number of mapped objects into this RPDO depends on the hardware.

Table 15 — Object description

Attribute	Value
INDEX	1601 _h
Name	RPDO 2mapping parameter
Object code	Record
Data type	PDO mapping parameter record
Category	Conditional: Mandatory, if 1401 _h is implemented

Table 16 — Entry description

Attribute	Value
Sub-Index	00 _h
Description	Highest sub-index supported
Access	rw
Entry category	Mandatory
PDO mapping	No
Value range	01 _h to 04 _h
Default value	01 _h to 04 _h

Sub-Index	01 _h
Description	1 st application object
Access	rw
Entry category	Mandatory
PDO mapping	No
Value range	See /CiA301/
Default value	6411 01 10 _h
Sub-Index	02 _h
Description	2 nd application object
Access	rw
Entry category	Conditional: Mandatory, if object 6411 02 _h is implemented
PDO mapping	No
Value range	See /CiA301/
Default value	6411 02 10 _h
to	
Sub-Index	04 _h
Description	4 th application object
Access	rw
Entry category	Conditional: Mandatory, if object 6411 04 _h is implemented
PDO mapping	No
Value range	See /CiA301/
Default value	6411 04 10 _h

6.2.7 TPDO 2 (analogue inputs)

This TPDO transmits event-driven the 16-bit values of maximum 4 analogue inputs. By default the interrupt source (6423_h object) shall be disabled. If one of the mapped analogue input changes its value and 6423_h object is enabled, the PDO is transmitted immediately. If an analogue interrupt condition is enabled, the PDO is transmitted only if this interrupt condition is fulfilled. If more than one interrupt condition is enabled; the PDO is transmitted if one of these conditions is fulfilled.

Table 17 defines the object description and Table 18 defines the entry description of the TPDO communication parameter. The values are defined in /CiA301/. The sub-index 04_h is reserved for compatibility reasons and shall not be implemented.

Table 17 — Object description

Attribute	Value
INDEX	1801 _h
Name	TPDO 2 communication parameter
Object code	Record
Data type	PDO communication parameter record
Category	Conditional: Mandatory, if M-bit in object 1000 _h is set to 0 _b and bit 18 in object 1000 _h is set to 1 _b

Table 18 — Entry description

Attribute	Value
Sub-Index	00 _h
Description	Highest sub-index supported
Access	ro
Entry category	Mandatory
PDO mapping	No
Value range	02 _h to 05 _h
Default value	Manufacturer-specific
Sub-Index	01 _h
Description	COB-ID
Access	rw
Entry category	Mandatory
PDO mapping	No
Value range	See /CiA301/
Default value	{0000 0280 _h , 4000 0280 _h } + node-ID
Sub-Index	02 _h
Description	Transmission type
Access	rw
Entry category	Mandatory
PDO mapping	No
Value range	See /CiA301/
Default value	255 _d
Sub-Index	03 _h
Description	Inhibit time
Access	rw
Entry category	Optional
PDO mapping	No
Value range	See /CiA301/
Default value	00 _h
Sub-Index	05 _h
Description	Event timer
Access	rw
Entry category	Optional
PDO mapping	No
Value range	See /CiA301/
Default value	00 _h

Table 19 defines the object description and Table 20 defines the entry description of the TPDO mapping parameter. The number of mapped objects into this TPDO depends on the hardware.

Table 19 — Object description

Attribute	Value
INDEX	1A01 _h
Name	TPDO 2 mapping parameter
Object code	Record
Data type	PDO mapping parameter record
Category	Conditional: Mandatory, if 1801 _h is implemented

Table 20 — Entry description

Attribute	Value
Sub-Index	00 _h
Description	Highest sub-index supported
Access	rw
Entry category	Mandatory
PDO mapping	No
Value range	01 _h to 04 _h
Default value	01 _h to 04 _h
Sub-Index	01 _h
Description	1 st application object
Access	rw
Entry category	Mandatory
PDO mapping	No
Value range	See /CiA301/
Default value	6401 01 10 _h
Sub-Index	02 _h
Description	2 nd application object
Access	rw
Entry category	Conditional: Mandatory, if object 6401 02 _h is implemented
PDO mapping	No
Value range	See /CiA301/
Default value	6401 02 10 _h
to	
Sub-Index	04 _h
Description	4 th application object
Access	rw
Entry category	Conditional: Mandatory, if object 6401 04 _h is implemented
PDO mapping	No
Value range	See /CiA301/
Default value	6401 04 10 _h

6.2.8 RPDO 3 (additional analogue outputs)

This RPDO receives asynchronously the 16-bit values of maximum 4 analogue outputs.

NOTE After power-on and application reset the values of the mapped outputs are as the default values or the stored values after configuration (stored values overwrites default values).

Table 21 defines the object description and Table 22 defines the entry description of the RPDO communication parameter.

Table 21 — Object description

Attribute	Value
INDEX	1402 _h
Name	RPDO 3 communication parameter
Object code	Record
Data type	PDO communication parameter record
Category	Conditional: Mandatory, if M-bit in object 1000 _h is set to 0 _b , bit 19 in object 1000 _h is set to 1 _b and more than 4 analogue outputs are implemented

Table 22 — Entry description

Attribute	Value
Sub-Index	00 _h
Description	Highest sub-index supported
Access	ro
Entry category	Mandatory
PDO mapping	No
Value range	02 _h
Default value	02 _h
Sub-Index	01 _h
Description	COB-ID
Access	rw
Entry category	Mandatory
PDO mapping	No
Value range	See /CiA301/
Default value	0000 0400 _h + node-ID
Sub-Index	02 _h
Description	Transmission type
Access	rw
Entry category	Mandatory
PDO mapping	No
Value range	See /CiA301/
Default value	255 _d

Table 23 defines the object description and Table 24 defines the entry description of the RPDO mapping parameter. The number of mapped objects into this RPDO depends on the hardware.

Table 23 — Object description

Attribute	Value
INDEX	1602 _h
Name	RPDO 3 mapping parameter
Object code	Record
Data type	PDO mapping parameter record
Category	Conditional: Mandatory, if 1402 _h is implemented

Table 24 — Entry description

Attribute	Value
Sub-Index	00 _h
Description	Highest sub-index supported
Access	rw
Entry category	Mandatory
PDO mapping	No
Value range	01 _h to 04 _h
Default value	01 _h to 04 _h
Sub-Index	01 _h
Description	1 st application object
Access	rw
Entry category	Mandatory
PDO mapping	No
Value range	See /CiA301/
Default value	6411 05 10 _h
Sub-Index	02 _h
Description	2 nd application object
Access	rw
Entry category	Conditional: Mandatory, if object 6411 06 _h is implemented
PDO mapping	No
Value range	See /CiA301/
Default value	6411 06 10 _h
to	
Sub-Index	04 _h
Description	4 th application object
Access	rw
Entry category	Conditional: Mandatory, if object 6411 08 _h is implemented
PDO mapping	No
Value range	See /CiA301/
Default value	6411 08 10 _h

6.2.9 TPDO 3 (additional analogue inputs)

This TPDO transmits event-driven the 16-bit values of maximum 4 analogue inputs. By default the interrupt source (6423_h object) is disabled. If one of the mapped analogue input changes its value and 6423_h object is enabled, the PDO is transmitted immediately. If an analogue interrupt condition is enabled; the PDO is transmitted only if this interrupt condition is fulfilled. If more than one interrupt condition is enabled; the PDO is transmitted if one of these conditions is fulfilled.

Table 25 defines the object description and Table 26 defines the entry description of the TPDO communication parameter. The values are defined in /CiA301/. The sub-index 04_h is reserved for compatibility reasons and shall not be implemented.

Table 25 — Object description

Attribute	Value
INDEX	1802 _h
Name	TPDO 3 communication parameter
Object code	Record
Data type	PDO communication parameter record
Category	Conditional: Mandatory, if M-bit in object 1000 _h is set to 0 _b , bit 18 in object 1000 _h is set to 1 _b and more than 4 analogue inputs are implemented

Table 26 — Entry description

Attribute	Value
Sub-Index	00 _h
Description	Highest sub-index supported
Access	ro
Entry category	Mandatory
PDO mapping	No
Value range	02 _h to 05 _h
Default value	Manufacturer-specific
Sub-Index	01 _h
Description	COB-ID
Access	rw
Entry category	Mandatory
PDO mapping	No
Value range	See /CiA301/
Default value	{0000 0380 _h , 4000 0380 _h } + node-ID
Sub-Index	02 _h
Description	Transmission type
Access	rw
Entry category	Mandatory
PDO mapping	No
Value range	See /CiA301/
Default value	255 _d

Sub-Index	03 _h
Description	Inhibit timer
Access	rw
Entry category	Optional
PDO mapping	No
Value range	See /CiA301/
Default value	00 _h
Sub-Index	05 _h
Description	Event timer
Access	rw
Entry category	Optional
PDO mapping	No
Value range	See /CiA301/
Default value	00 _h

Table 27 defines the object description and Table 28 defines the entry description of the TPDO mapping parameter. The number of mapped objects into this TPDO depends on the hardware.

Table 27 — Object description

Attribute	Value
INDEX	1A02 _h
Name	TPDO 3 mapping parameter
Object code	Record
Data type	PDO mapping parameter record
Category	Conditional: Mandatory, if 1802 _h is implemented

Table 28 — Entry description

Attribute	Value
Sub-Index	00 _h
Description	Highest sub-index supported
Access	rw
Entry category	Mandatory
PDO mapping	No
Value range	01 _h to 04 _h
Default value	01 _h to 04 _h

Sub-Index	01 _h
Description	1 st application object
Access	rw
Entry category	Mandatory
PDO mapping	No
Value range	See /CiA301/
Default value	6401 05 10 _h
to	
Sub-Index	02 _h
Description	2 nd application object
Access	rw
Entry category	Conditional: Mandatory, if object 6401 06 _h is implemented
PDO mapping	No
Value range	See /CiA301/
Default value	6401 06 10 _h
to	
Sub-Index	04 _h
Description	4 th application object
Access	rw
Entry category	Conditional: Mandatory, if object 6401 08 _h is implemented
PDO mapping	No
Value range	See /CiA301/
Default value	6401 08 10 _h

6.2.10 RPDO 4 (additional analogue outputs)

This RPDO receives asynchronously the 16-bit values of maximum 4 analogue outputs. The default transmission type shall be 255.

Note After power-on and application reset the values of the mapped outputs are as the default values or the stored values after configuration (stored values overwrites default values).

Table 29 defines the object description and Table 30 defines the entry description of the RPDO communication parameter.

Table 29 — Object description

Attribute	Value
INDEX	1403 _h
Name	RPDO 4 communication parameter
Object code	Record
Data type	PDO communication parameter record
Category	Conditional: Mandatory, if M-bit in object 1000 _h is set to 0 _b , bit 19 in object 1000 _h is set to 1 _b and more than 8 analogue outputs are implemented

Table 30 — Entry description

Attribute	Value
-----------	-------

Device profile for generic I/O modules

Sub-Index	00 _h
Description	Highest sub-index supported
Access	ro
Entry category	Mandatory
PDO mapping	No
Value range	02 _h
Default value	02 _h
Sub-Index	01 _h
Description	COB-ID
Access	rw
Entry category	Mandatory
PDO mapping	No
Value range	See /CiA301/
Default value	0000 0500 _h + node-ID
Sub-Index	02 _h
Description	Transmission type
Access	rw
Entry category	Mandatory
PDO mapping	No
Value range	See /CiA301/
Default value	255 _d

Table 31 defines the object description and Table 32 defines the entry description of the RPDO mapping parameter. The number of mapped objects into this RPDO depends on the hardware.

Table 31 — Object description

Attribute	Value
INDEX	1603 _h
Name	RPDO 4 mapping parameter
Object code	Record
Data type	PDO mapping parameter record
Category	Conditional: Mandatory, if 1403 _h is implemented

Table 32 — Entry description

Sub-Index	00 _h
Description	Highest sub-index supported
Access	rw
Entry category	Mandatory
PDO mapping	No
Value range	01 _h to 04 _h
Default value	01 _h to 04 _h

Sub-Index	01 _h
Description	1 st application object
Access	rw
Entry category	Mandatory
PDO mapping	No
Value range	See /CiA301/
Default value	6411 09 10 _h
Sub-Index	02 _h
Description	2 nd application object
Access	rw
Entry category	Conditional: Mandatory, if object 6411 0A _h is implemented
PDO mapping	No
Value range	See /CiA301/
Default value	6411 0A 10 _h
to	
Sub-Index	04 _h
Description	4 th application object
Access	rw
Entry category	Conditional: Mandatory, if object 6411 0C _h is implemented
PDO mapping	No
Value range	See /CiA301/
Default value	6411 0C 10 _h

6.2.11 TPDO 4 (additional analogue inputs)

This TPDO transmits event-driven the 16-bit values of maximum 4 analogue inputs. By default the interrupt source (6423_h object) is disabled. If one of the mapped analogue input changes its value and 6423_h object is enabled, the PDO is transmitted immediately. If an analogue interrupt condition is enabled; the PDO is transmitted only if this interrupt condition is fulfilled. If more than one interrupt condition is enabled; the PDO is transmitted if one of these conditions is fulfilled.

Table 33 defines the object description and Table 34 defines the entry description of the TPDO communication parameter. The values are defined in /CiA301/. The sub-index 04_h is reserved for compatibility reasons and shall not be implemented.

Table 33 — Object description

Attribute	Value
INDEX	1803 _h
Name	TPDO 4 communication parameter
Object code	Record
Data type	PDO communication parameter record
Category	Conditional: Mandatory, if M-bit in object 1000 _h is set to 0 _b , bit 18 in object 1000 _h is set to 1 _b and more than 8 analogue inputs are implemented

Table 34 — Entry description

Attribute	Value
Sub-Index	00 _h
Description	Highest sub-index supported
Access	ro
Entry category	Mandatory
PDO mapping	No
Value range	02 _h to 05 _h
Default value	Manufacturer-specific
Sub-Index	01 _h
Description	COB-ID
Access	rw
Entry category	Mandatory
PDO mapping	No
Value range	See /CiA301/
Default value	{0000 0480 _h , 4000 0480 _h } + node-ID
Sub-Index	02 _h
Description	Transmission type
Access	rw
Entry category	Mandatory
PDO mapping	No
Value range	See /CiA301/
Default value	255 _d
Sub-Index	03 _h
Description	Inhibit time
Access	rw
Entry category	Optional
PDO mapping	No
Value range	See /CiA301/
Default value	00 _h
Sub-Index	05 _h
Description	Event timer
Access	rw
Entry category	Optional
PDO mapping	No
Value range	See /CiA301/
Default value	00 _h

Table 35 defines the object description and Table 36 defines the entry description of the TPDO mapping parameter. The number of mapped objects into this TPDO depends on the hardware.

Table 35 — Object description

Attribute	Value
INDEX	1A03 _h
Name	TPDO 4 mapping parameter
Object code	Record
Data type	PDO mapping
Category	Conditional: Mandatory, if 1803 _h is implemented

Table 36 — Entry description

Attribute	Value
Sub-Index	00 _h
Description	Highest sub-index supported
Access	rw
Entry category	Mandatory
PDO mapping	No
Value range	01 _h to 04 _h
Default value	01 _h to 04 _h
Sub-Index	01 _h
Description	1 st application object
Access	rw
Entry category	Mandatory
PDO mapping	No
Value range	See /CiA301/
Default value	6401 09 10 _h
Sub-Index	02 _h
Description	2 nd application object
Access	rw
Entry category	Conditional: Mandatory, if object 6401 0A _h is implemented
PDO mapping	No
Value range	See /CiA301/
Default value	6401 0A 10 _h
to	
Sub-Index	04 _h
Description	4 th application object
Access	rw
Entry category	Conditional: Mandatory, if object 6401 0C _h is implemented
PDO mapping	No
Value range	See /CiA301/
Default value	6401 0C 10 _h

6.2.12 Manufacturer-specific PDOs

RPDO 5 to 512 and TPDO 5 to 512 are manufacturer-specific. They shall not be enabled by default.

7 Object dictionary

7.1 Introduction

Each I/O module compliant with this device profile shall share the CANopen object dictionary entries from 6000_h to 67FF_h. These entries are common to all I/O modules and each module only implements those objects relevant to its functions.

NOTE The manufacturer may add application-specific objects (2000_h to 5FFF_h) in order to provide manufacturer-specific functionality.

7.2 Input and output function principles

7.2.1 Object dictionary for the digital input and output modules

7.2.1.1 Command sequence

It is possible to switch the modules output or input polarity. This feature is the one which is nearest to the sensors and actuators, e.g. if the polarity of an output is enabled and the output is set to high, then the output level is '0'.

Table 37 defines the profile command sequence.

Table 37 — Profile command sequence

Commands	Polarity switch	Process
Read input	enabled: 0 change to 1	Sensor or actuator
Write output	1 change to 0	
Interrupt mask	disabled: 0 remains 0	
Error mode	1 remains 1	

Figure 2 shows an example of the polarity with a digital output.

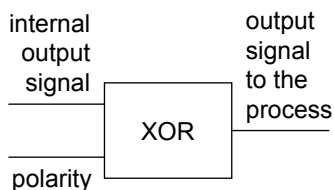

Figure 2 — Polarity bit for digital outputs (example)

7.2.1.2 1-, 8-, 16- and 32-bit access

There are different objects to allow 1-bit, 8-bit, 16-bit or 32-bit access to digital inputs or outputs (e.g. definition of polarity). If these objects define the same function, they access single database. Example: If the 6002_h object (change polarity input 8-bit) sub-index 1_n has the value AA_h and sub-index 2_n the value 0F_h, 6102_h object (change polarity input 16-bit) sub-index 1_n shall have the value 0FAA_h.

7.2.1.3 I/O channel to sub-index relation

The bit position shall be calculated by the following formula:

$$\text{Bit position} = (\text{I/O channel no.} - 1) \text{ MOD } (\text{length of data type})$$

The sub-index, where a bit is located, shall be calculated by the following formula:

$$\text{Sub-index} = (\text{I/O channel no.} - 1) \text{ DIV } (\text{length of data type}) + 1$$

Figure 3 shows an example.

Sub-index 01_h

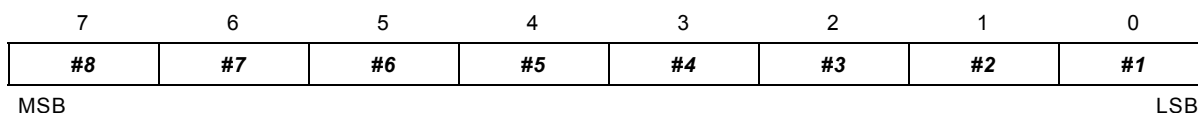

Sub-index 02_h

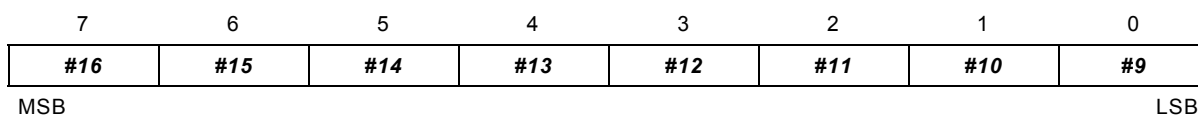

Figure 3 — Example for 8-bit access

7.2.2 Digital input module

There are different access methods defined. By default, 8-bit access shall be supported; the other access methods are optional. Figure 4 shows the relationship between the digital input objects for an 8-bit access.

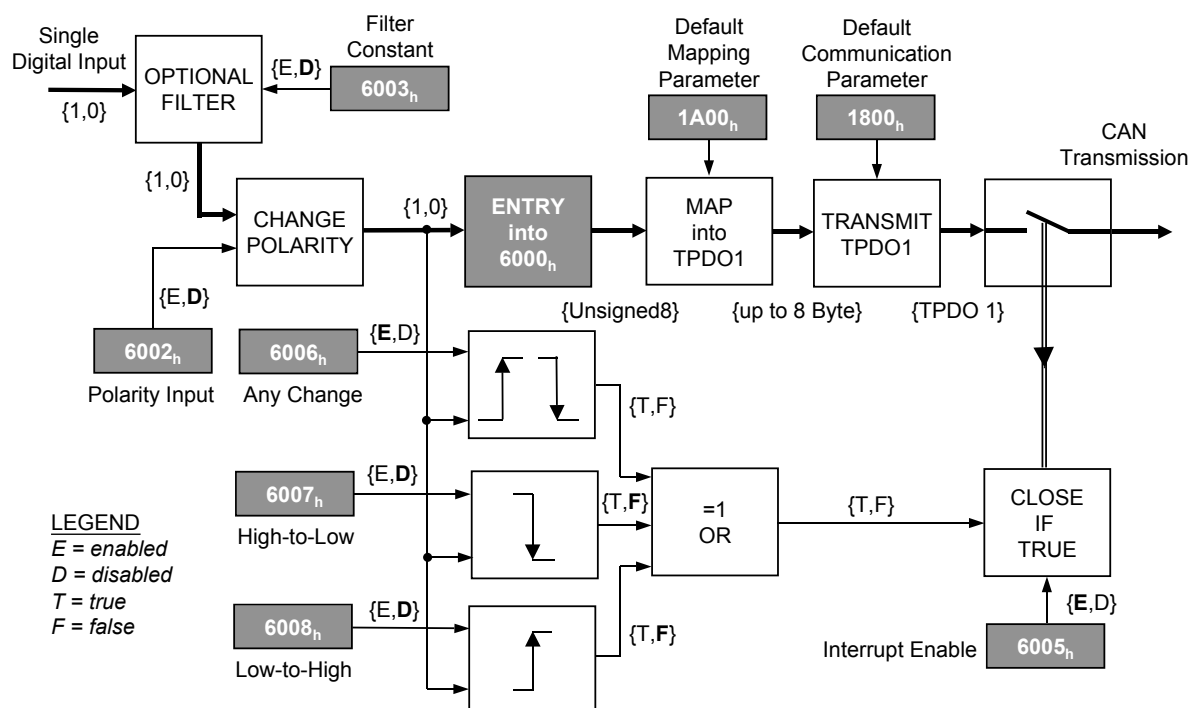

Figure 4 — Block diagram for digital inputs

7.2.3 Digital output module

There are different access methods defined. By default, 8-bit access shall be supported; the other access methods are optional. Figure 5 shows the relationship between the digital output objects for an 8-bit access.

NOTE 1 After power-on or NMT reset application the write output objects are in default state. The digital output application only accepts digital output settings after the device has received the first heartbeat from the device that sets the outputs, or the NMT master has node guarded the device for the first time.

NOTE 2 Device internal failures that cause the digital outputs to error states include Heartbeat events from the device that sets the outputs, or Life guarding events. If node/life guarding is used and the device with NMT master capability is not the digital output setting device, the Node guarding application is responsible to stop the guarding of the digital output device.

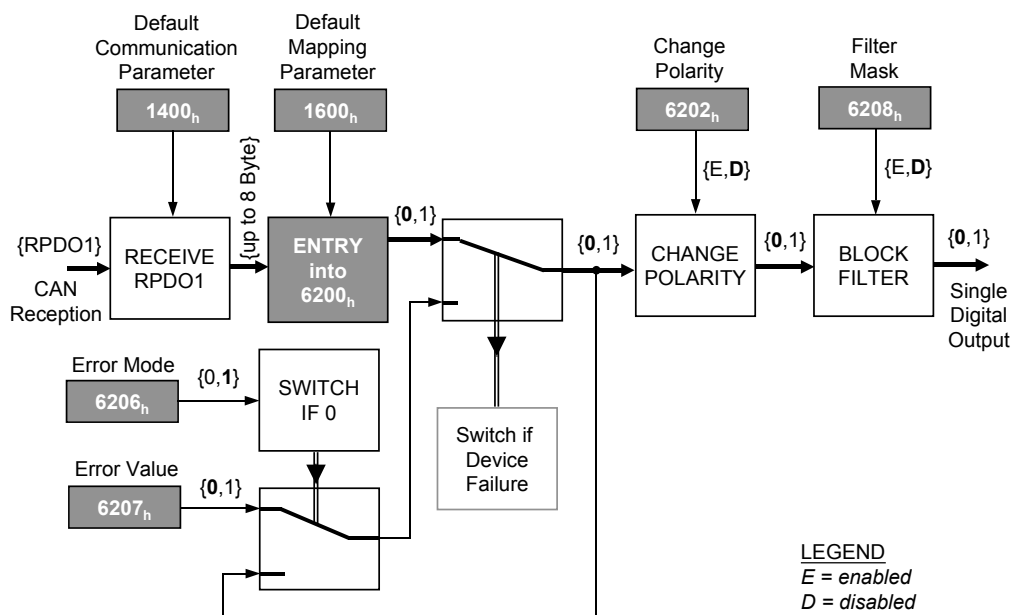

Figure 5 — Block diagram for digital outputs

7.2.4 Analogue input module

There are different access methods defined. By default, 16-bit access shall be supported; the other access methods are optional. Figure 6 shows the relationship between the analogue input objects for 16-bit access.

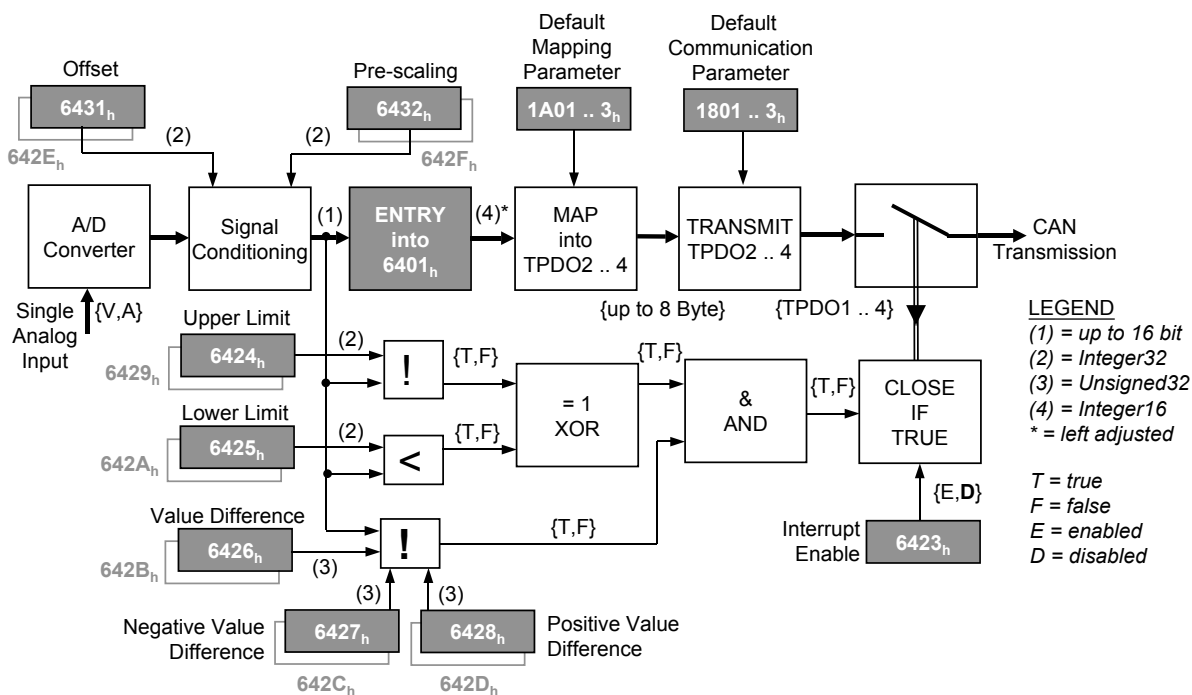

Figure 6 — Block diagram for analogue inputs

7.2.5 Analogue output module

There are different access methods defined. By default, 16-bit access shall be supported; the other access methods are optional. Figure 7 shows the relationship between the analogue output objects for 16-bit access.

NOTE 1 After power-on or NMT reset application the write analogue output objects are in default state. The analogue output application only accepts analogue output settings after the device has received the first heartbeat from the device that sets the outputs, or the NMT master has node guarded the device for the first time.

NOTE 2 Device internal failures that cause the analogue outputs to error states include Heartbeat events from the device that sets the outputs, or Life guarding events. If node/life guarding is used and the device with NMT master capability is not the analogue output setting device, the Node guarding application is responsible to stop the guarding of the analog output device.

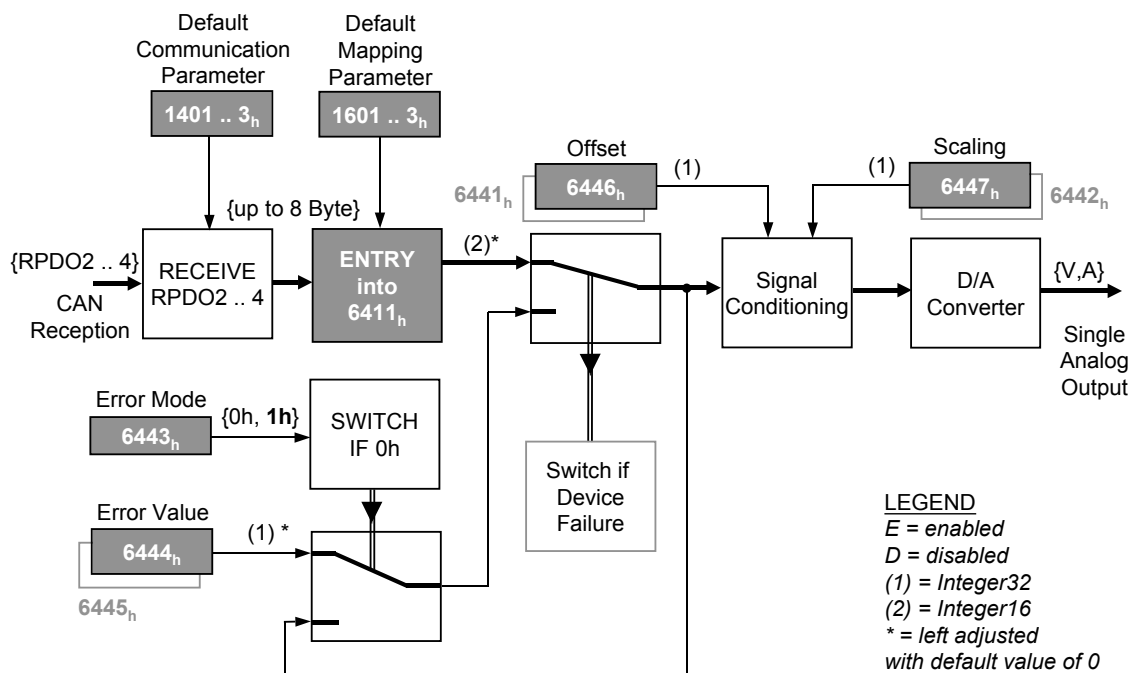

Figure 7 — Block diagram for analogue outputs

8 Detailed object definitions

8.1 Introduction

Each object is defined by the object and entry descriptions. The attribute values for object and entry descriptions are specified in /CiA301/.

8.2 Digital input module

8.2.1 Object 6000_h: Read input 8-bit

This object shall read groups of 8 input lines as 8-bit information. A maximum of 254 x 8-bit inputs is addressable (2032 inputs). This object is mandatory for digital input modules and shall support all implemented input lines.

Table 38 specifies the object description, and Table 39 specifies the entry description.

Table 38 — Object description

Attribute	Value
INDEX	6000 _h
Name	Read input 8 bit
Object code	Array
Data type	Unsigned8
Category	Conditional: Device with digital inputs

Table 39 — Entry description

Attribute	Value
Sub-Index	00 _h
Description	Number of inputs 8-bit
Access	ro
Entry category	Mandatory
PDO mapping	No
Value range	01 _h to FE _h
Default value	Device-specific
Sub-Index	01 _h
Description	Read input 01 _h to 08 _h
Access	ro
Entry category	Mandatory
PDO mapping	Default
Value range	Unsigned8
Default value	No
Sub-Index	02 _h
Description	Read input 09 _h to 10 _h
Access	ro
Entry category	Optional
PDO mapping	Default
Value range	Unsigned8
Default value	No
to	
Sub-Index	08 _h
Description	Read input 39 _h to 40 _h
Access	ro
Entry category	Optional
PDO mapping	Default
Value range	Unsigned8
Default value	No
Sub-Index	09 _h
Description	Read input 41 _h to 48 _h
Access	ro
Entry category	Optional
PDO mapping	Optional
Value range	Unsigned8
Default value	No
to	

Sub-Index	FE _h
Description	Read input 7E8 _h to 7F0 _h
Access	ro
Entry category	Optional
PDO mapping	Optional
Value range	Unsigned8
Default value	No

8.2.2 Object 6002_h: Polarity input 8-bit

This object shall define the polarity of a group of 8 input lines. Input polarity can be inverted individually.

1 = input inverted 0 = input not inverted

If the object is not supported the device shall behave accordingly to the default value.

Table 40 specifies the object description, and Table 41 specifies the entry description.

Table 40 — Object description

Attribute	Value
INDEX	6002 _h
Name	Polarity input 8-bit
Object code	Array
Data type	Unsigned8
Category	Optional

Table 41 — Entry description

Attribute	Value
Sub-Index	00 _h
Description	Number of inputs 8-bit
Access	ro
Entry category	Mandatory
PDO mapping	No
Value range	01 _h to FE _h
Default value	No
Sub-Index	01 _h
Description	Polarity input 01 _h to 08 _h
Access	rw
Entry category	Mandatory
PDO mapping	Possible
Value range	Unsigned8
Default value	00 _h

Sub-Index	02 _h
Description	Polarity input 09 _h to 10 _h
Access	rw
Entry category	Optional
PDO mapping	Possible
Value range	Unsigned8
Default value	00 _h
to	
Sub-Index	FE _h
Description	Polarity input 7E8 _h to 7F0 _h
Access	rw
Entry category	Optional
PDO mapping	Optional
Value range	Unsigned8
Default value	00 _h

8.2.3 Object 6003_h: Filter constant input 8-bit

This object shall enable and disable an additional configurable filter constant. If the object is not supported, the device shall behave accordingly to the default value. The type of the filter constant and the configuration of the filter constant are manufacturer-specific.

1 = enabled 0 = disabled

Table 42 specifies the object description, and Table 43 specifies the entry description.

Table 42 — Object description

Attribute	Value
INDEX	6003 _h
Name	Filter constant input 8-bit
Object code	Array
Data type	Unsigned8
Category	Optional

Table 43 — Entry description

Attribute	Value
Sub-Index	00 _h
Description	Number of inputs 8-bit
Access	ro
Entry category	Mandatory
PDO mapping	No
Value range	01 _h to FE _h
Default value	No

Sub-Index	01 _h
Description	Filter constant input 01 _h to 08 _h
Access	rw
Entry category	Mandatory
PDO mapping	Optional
Value range	Unsigned8
Default value	00 _h
to	
Sub-Index	02 _h
Description	Filter constant input 09 _h to 10 _h
Access	rw
Entry category	Optional
PDO mapping	Optional
Value range	Unsigned8
Default value	00 _h
to	
Sub-Index	FE _h
Description	Filter constant input 7E8 _h to 7F0 _h
Access	rw
Entry category	Optional
PDO mapping	Optional
Value range	Unsigned8
Default value	00 _h

8.2.4 Object 6005_h: Global interrupt enable digital 8-bit

This object shall enable and disable globally the interrupt behavior without changing the interrupt masks. In event-driven mode the device transmits the input values depending on the interrupt masks in objects 6006_h, 6007_h, and 6008 (resp. 6050_h to 6057_h, 6060_h to 6067_h, 6070_h to 6077_h, or 6106_h, 6107_h, 6108_h, or 6126_h, 6127_h, 6127_h) and the PDO transmission type. If the object is not supported, the device shall behave accordingly to the default value.

TRUE = global interrupt enabled

FALSE = global interrupt disabled

Table 44 specifies the object description, and Table 45 specifies the entry description.

Table 44 — Object description

Attribute	Value
INDEX	6005 _h
Name	Global interrupt enable digital 8-bit
Object code	Variable
Data type	Boolean
Category	Optional

Table 45 — Entry description

Attribute	Value
Sub-Index	00 _h
Access	rw
PDO mapping	No
Value range	Boolean
Default value	TRUE

8.2.5 Object 6006_h: Interrupt mask any change 8-bit

This object determines, which input port lines shall activate an interrupt by positive or/and negative edge detection.

If the object is not supported the device shall behave accordingly to the default value.

Table 46 specifies the object description, Table 47 and specifies the entry description.

Table 46 — Object description

Attribute	Value
INDEX	6006 _h
Name	Interrupt mask any change 8-bit
Object code	Array
Data type	Unsigned8
Category	Optional

Table 47 — Entry description

Attribute	Value
Sub-Index	00 _h
Description	Number of inputs 8-bit
Access	ro
Entry category	Mandatory
PDO mapping	No
Value range	01 _h to FE _h
Default value	No
Sub-Index	01 _h
Description	Interrupt any change 01 _h to 08 _h
Access	rw
Entry category	Mandatory
PDO mapping	Optional
Value range	Unsigned8
Default value	FF _h

Sub-Index	02 _h
Description	Interrupt any change 09 _h to 10 _h
Access	rw
Entry category	Optional
PDO mapping	Optional
Value range	Unsigned8
Default value	FF _h
to	
Sub-Index	FE _h
Description	Interrupt any change 7E8 _h to 7F0 _h
Access	rw
Entry category	Optional
PDO mapping	Optional
Value range	Unsigned8
Default value	FF _h

8.2.6 Object 6007_h: Interrupt mask low-to-high 8-bit

This object determines, which input port lines shall activate an interrupt by positive edge detection (logical 0 to 1). Done for groups of 8 lines. The values shall be in an "OR" connection to the values of 6006_h object (Interrupt mask any change 8-bit). If inputs are inverted by 6002_h object (polarity input 8-bit), the positive logical edge shall correspond to negative physical edge.

1 = interrupt enabled 0 = interrupt disabled

Table 48 specifies the object description, and Table 49 specifies the entry description.

Table 48 — Object description

Attribute	Value
INDEX	6007 _h
Name	Interrupt mask low-to-high 8-bit
Object code	Array
Data type	Unsigned8
Category	Optional

Table 49 — Entry description

Attribute	Value
Sub-Index	00 _h
Description	Number of inputs 8-bit
Access	ro
Entry category	Mandatory
PDO mapping	No
Value range	01 _h to FE _h
Default value	No

Sub-Index	01 _h
Description	Interrupt low-to-high 01 _h to 08 _h
Access	rw
Entry category	Mandatory
PDO mapping	Optional
Value range	Unsigned8
Default value	00 _h
Sub-Index	02 _h
Description	Interrupt low-to-high 09 _h to 10 _h
Access	rw
Entry category	Optional
PDO mapping	Optional
Value range	Unsigned8
Default value	00 _h
to	
Sub-Index	FE _h
Description	Interrupt low-to-high 7E8 _h to 7F0 _h
Access	rw
Entry category	Optional
PDO mapping	Optional
Value range	Unsigned8
Default value	00 _h

8.2.7 Object 6008_h: Interrupt mask high-to-low 8-bit

This object determines, which input port lines shall activate an interrupt by negative edge detection (logical 1 to 0). Done for groups of 8 lines. The values shall be in an "OR" connection to the values of 6006_h object (Interrupt mask any change 8-bit). If inputs are inverted by 6002_h object (polarity input 8-bit), the negative logical edge shall correspond to positive physical edge.

1 = interrupt enabled 0 = interrupt disabled

Table 50 specifies the object description, and Table 51 specifies the entry description.

Table 50 — Object description

Attribute	Value
INDEX	6008 _h
Name	Interrupt mask high-to-low 8-bit
Object code	Array
Data type	Unsigned8
Category	Optional

Table 51 — Entry description

Attribute	Value
Sub-Index	00 _h
Description	Number of inputs 8-bit
Access	ro
Entry category	Mandatory
PDO mapping	No
Value range	01 _h to FE _h
Default value	No
Sub-Index	01 _h
Description	Interrupt high-to-low 01 _h to 08 _h
Access	rw
Entry category	Mandatory
PDO mapping	Optional
Value range	Unsigned8
Default value	00 _h
Sub-Index	02 _h
Description	Interrupt high-to-low 09 _h to 10 _h
Access	rw
Entry category	Optional
PDO mapping	Optional
Value range	Unsigned8
Default value	00 _h
to	
Sub-Index	FE _h
Description	Interrupt high-to-low 7F1 _h to 7F8 _h
Access	rw
Entry category	Optional
PDO mapping	Optional
Value range	Unsigned8
Default value	00 _h

8.2.8 Object 6020_h to 6027_h: Read input bit 1 to 128 to read input bit 897 to 1024

These objects shall read single input lines information. A maximum of 128 input lines is addressable at one index. The 6020_h object shall address the input lines 1 to 128, the 6021_h object shall address the input lines 129 to 256, etc.

Table 52 specifies the object description, and Table 53 specifies the entry description.

Table 52 — Object description

Attribute	Value
INDEX	6020 _h
Name	Read input bit 01 _h to 80 _h
Object code	Array
Data type	Boolean
Category	Optional

Table 53 — Entry description

Attribute	Value
Sub-Index	00 _h
Description	Number of inputs 1-bit
Access	ro
Entry category	Mandatory
PDO mapping	No
Value range	01 _h to 80 _h
Default value	No
Sub-Index	01 _h
Description	Read single input 01 _h
Access	ro
Entry category	Mandatory
PDO mapping	Optional
Value range	Boolean
Default value	No
Sub-Index	02 _h
Description	Read single input 02 _h
Access	ro
Entry category	Optional
PDO mapping	Optional
Value range	Boolean
Default value	No
to	
Sub-Index	80 _h
Description	Read single input 80 _h
Access	ro
Entry category	Optional
PDO mapping	Optional
Value range	Boolean
Default value	No

8.2.9 Object 6030_h to 6037_h: Polarity input bit 1 to 128 to polarity input bit 897 to 1024

These objects shall define the polarity of single input lines. A maximum of 128 input lines is addressable at one index. The 6030_h object shall address the input lines 1 to 128, the 6031_h object shall address the input lines 129 to 256, etc.

TRUE = input inverted FALSE = input not inverted

If these objects are not supported the device shall behave accordingly to the default value.

Table 54 specifies the object description, and Table 55 specifies the entry description.

Table 54 — Object description

Attribute	Value
INDEX	6030 _h
Name	Polarity input bit 01 _h to 80 _h
Object code	Array
Data type	Boolean
Category	Optional

Table 55 — Entry description

Attribute	Value
Sub-Index	00 _h
Description	Number of inputs 1-bit
Access	ro
Entry category	Mandatory
PDO mapping	No
Value range	01 _h to 80 _h
Default value	No
Sub-Index	01 _h
Description	Polarity input bit 01 _h
Access	rw
Entry category	Mandatory
PDO mapping	Optional
Value range	Boolean
Default value	FALSE
Sub-Index	02 _h
Description	Polarity input bit 02 _h
Access	rw
Entry category	Optional
PDO mapping	Optional
Value range	Boolean
Default value	FALSE
to	

Sub-Index	80 _h
Description	Polarity input bit 80 _h
Access	rw
Entry category	Optional
PDO mapping	Optional
Value range	Boolean
Default value	FALSE

8.2.10 Object 6038_h to 603F_h: Filter constant input bit 1 to 128 to filter constant input bit 897 to 1024

These objects shall enable and disable an additional configurable filter constant. If these objects are not supported, the device shall behave accordingly to the default value. The type of the filter constant and the configuration of the filter constant are manufacturer-specific. The 6038_h object shall address the input lines 1 to 128, the 6039_h object shall address the input lines 129 to 256, etc.

TRUE = enabled FALSE = disable

Table 56 specifies the object description, and Table 57 specifies the entry description.

Table 56 — Object description

Attribute	Value
INDEX	6038 _h
Name	Filter constant input bit 01 _h to 80 _h
Object code	Array
Data type	Boolean
Category	Optional

Table 57 — Entry description

Attribute	Value
Sub-Index	00 _h
Description	Number of inputs 1-bit
Access	ro
Entry category	Mandatory
PDO mapping	No
Value range	01 _h to 80 _h
Default value	No
Sub-Index	01 _h
Description	Filter constant input bit 01 _h
Access	rw
Entry category	Mandatory
PDO mapping	Optional
Value range	Boolean
Default value	FALSE

Sub-Index	02 _h
Description	Filter constant input bit 02 _h
Access	rw
Entry category	Optional
PDO mapping	Optional
Value range	Boolean
Default value	FALSE
to	
Sub-Index	80 _h
Description	Filter constant input bit 80 _h
Access	rw
Entry category	Optional
PDO mapping	Optional
Value range	Boolean
Default value	FALSE

8.2.11 Object 6050_h to 6057_h: Interrupt mask input bit any change 1 to 128 to interrupt mask input bit any change 897 to 1024

These objects shall set interrupt masks for single input lines. A maximum of 128 bit inputs is addressable at one index. The 6050_h object shall address the input lines 1 to 128, the 6051_h object shall address the input lines 129 to 256, etc.

TRUE = interrupt enabled FALSE = interrupt disabled

If the object is not supported, the device shall behave accordingly to the default value.

Table 58 specifies the object description, and Table 59 specifies the entry description.

Table 58 — Object description

Attribute	Value
INDEX	6050 _h
Name	Interrupt mask input bit any change 01 _h to 80 _h
Object code	Array
Data type	Boolean
Category	Optional

Table 59 — Entry description

Attribute	Value
Sub-Index	00 _h
Description	Number of inputs 1-bit
Access	ro
Entry category	Mandatory
PDO mapping	No
Value range	01 _h to 80 _h
Default value	No

Sub-Index	01 _h
Description	Interrupt mask any change input bit 01 _h
Access	rw
Entry category	Mandatory
PDO mapping	Optional
Value range	Boolean
Default value	TRUE
to	
Sub-Index	02 _h
Description	Interrupt mask any change input bit 02 _h
Access	rw
Entry category	Optional
PDO mapping	Optional
Value range	Boolean
Default value	TRUE
to	
Sub-Index	80 _h
Description	Interrupt mask any change input bit 80 _h
Access	rw
Entry category	Optional
PDO mapping	Optional
Value range	Boolean
Default value	TRUE

8.2.12 Object 6060_h to 6067_h: Interrupt mask input low-to-high bit 1 to 128 to interrupt mask input low-to-high bit 897 to 1024

These objects shall set interrupt masks for a single input line. A maximum of 128 bit inputs is addressable at one index. The 6060_h object shall address the input lines 1 to 128, the 6061_h object shall address the input lines 129 to 256, etc. The values shall be in an "OR" connection to the values of 6050_h to 6057_h objects (interrupt mask any change). If inputs are inverted by 6030_h to 6037_h objects (polarity input), the positive logical edge shall correspond to negative physical edge.

TRUE = interrupt enabled FALSE = interrupt disabled

If the object is not supported, the device shall behave accordingly to the default value.

Table 60 specifies the object description, and Table 61 specifies the entry description.

Table 60 — Object description

Attribute	Value
INDEX	6060 _h
Name	Interrupt mask input low-to-high bit 01 _h to 80 _h
Object code	Array
Data type	Boolean
Category	Optional

Table 61 — Entry description

Attribute	Value
Sub-Index	00 _h
Description	Number of inputs 1-bit
Access	rw
Entry category	Mandatory
PDO mapping	No
Value range	01 _h to 80 _h
Default value	No
Sub-Index	01 _h
Description	Interrupt mask low-to-high input 01 _h
Access	rw
Entry category	Mandatory
PDO mapping	Optional
Value range	Boolean
Default value	FALSE
Sub-Index	02 _h
Description	Interrupt mask low-to-high input 02 _h
Access	rw
Entry category	Optional
PDO mapping	Optional
Value range	Boolean
Default value	FALSE
to	
Sub-Index	80 _h
Description	Interrupt mask low-to-high input 80 _h
Access	rw
Entry category	Optional
PDO mapping	Optional
Value range	Boolean
Default value	FALSE

8.2.13 Object 6070_h to 6077_h: Interrupt mask input high-to-low bit 1 to 128 to interrupt mask input high-to-low bit 897 to 1024

These objects shall set interrupt masks for single input lines. A maximum of 128 bit inputs is addressable at one index. The 6070_h object shall address the input lines 1 to 128, the 6071_h object shall address the input lines 129 to 256, etc. The values shall be in an "OR" connection to the values of 6050_h to 6057_h objects (interrupt mask any change). If inputs are inverted by 6030_h to 6037_h objects (polarity input), the negative logical edge shall correspond to positive physical edge.

TRUE = interrupt enabled FALSE = interrupt disabled

If the object is not supported, the device shall behave accordingly to the default value.

Table 62 specifies the object description, and Table 63 specifies the entry description.

Table 62 — Object description

Attribute	Value
INDEX	6070 _h
Name	Interrupt mask input high-to-low bit 01 _h to 80 _h
Object code	Array
Data type	Boolean
Category	Optional

Table 63 — Entry description

Attribute	Value
Sub-Index	00 _h
Description	Number of inputs 1-bit
Access	rw
Entry category	Mandatory
PDO mapping	No
Value range	01 _h to 80 _h
Default value	No
Sub-Index	01 _h
Description	Interrupt mask high-to-low input 01 _h
Access	rw
Entry category	Mandatory
PDO mapping	Optional
Value range	Boolean
Default value	FALSE
Sub-Index	02 _h
Description	Interrupt mask high-to-low input 02 _h
Access	rw
Entry category	Optional
PDO mapping	Optional
Value range	Boolean
Default value	FALSE
to	
Sub-Index	80 _h
Description	Interrupt mask high-to-low input 80 _h
Access	rw
Entry category	Optional
PDO mapping	Optional
Value range	Boolean
Default value	FALSE

8.2.14 Object 6100_h: Read input 16-bit

The object shall read a group of 16 input lines as 16-bit information. A maximum of 254 x 16-bit words is addressable (4064 inputs).

Table 64 specifies the object description, and Table 65 specifies the entry description.

Table 64 — Object description

Attribute	Value
INDEX	6100 _h
Name	Read input 16-bit
Object code	Array
Data type	Unsigned16
Category	Optional

Table 65 — Entry description

Attribute	Value
Sub-Index	00 _h
Description	Number of inputs 16-bit
Access	ro
Entry category	Mandatory
PDO mapping	No
Value range	01 _h to FE _h
Default value	No
Sub-Index	01 _h
Description	Read input 01 _h to 10 _h
Access	ro
Entry category	Mandatory
PDO mapping	Optional
Value range	Unsigned16
Default value	No
Sub-Index	02 _h
Description	Read input 11 _h to 20 _h
Access	ro
Entry category	Optional
PDO mapping	Optional
Value range	Unsigned16
Default value	No
to	

Sub-Index	FE _h
Description	Read input FD0 _h to FE0 _h
Access	ro
Entry category	Optional
PDO mapping	Optional
Value range	Unsigned16
Default value	No

8.2.15 Object 6102_h: Polarity input 16-bit

This object shall define the polarity for a group of 16 input lines. Inputs can be inverted individually.

1 = input inverted 0 = input not inverted

If the object is not supported the device shall behave accordingly to the default value.

Table 66 specifies the object description, and Table 67 specifies the entry description.

Table 66 — Object description

Attribute	Value
INDEX	6102 _h
Name	Polarity input 16-bit
Object code	Array
Data type	Unsigned16
Category	Optional

Table 67 — Entry description

Attribute	Value
Sub-Index	00 _h
Description	Number of inputs 16-bit
Access	ro
Entry category	Mandatory
PDO mapping	No
Value range	01 _h to FE _h
Default value	No
Sub-Index	01 _h
Description	Polarity input 01 _h to 10 _h
Access	rw
Entry category	Mandatory
PDO mapping	Optional
Value range	Unsigned16
Default value	0000 _h

Sub-Index	02 _h
Description	Polarity input 11 _h to 20 _h
Access	rw
Entry category	Optional
PDO mapping	Optional
Value range	Unsigned16
Default value	0000 _h
to	
Sub-Index	FE _h
Description	Polarity input FD1 _h to FF0 _h
Access	rw
Entry category	Optional
PDO mapping	Optional
Value range	Unsigned16
Default value	0000 _h

8.2.16 Object 6103_h: Filter constant input 16-bit

This object shall enable and disable an additional configurable filter constant. If the object is not supported, the device shall behave accordingly to the default value. The type of the filter constant and the configuration of the filter constant are manufacturer-specific.

1 = enabled 0 = disabled

Table 68 specifies the object description, and Table 69 specifies the entry description.

Table 68 — Object description

Attribute	Value
INDEX	6103 _h
Name	Filter constant input 16-bit
Object code	Array
Data type	Unsigned16
Category	Optional

Table 69 — Entry description

Attribute	Value
Sub-Index	00 _h
Description	Number of inputs 16-bit
Access	ro
Entry category	Mandatory
PDO mapping	No
Value range	01 _h to FE _h
Default value	No

Sub-Index	01 _h
Description	Filter constant input 01 _h to 10 _h
Access	rw
Entry category	Mandatory
PDO mapping	Optional
Value range	Unsigned16
Default value	0000 _h
Sub-Index	02 _h
Description	Filter constant input 11 _h to 20 _h
Access	rw
Entry category	Optional
PDO mapping	Optional
Value range	Unsigned16
Default value	0000 _h
to	
Sub-Index	FE _h
Description	Filter constant input FD1 _h to FE0 _h
Access	rw
Entry category	Optional
PDO mapping	Optional
Value range	Unsigned16
Default value	0000 _h

8.2.17 Object 6106_h: Interrupt mask input any change 16-bit

This object determines, which input port lines shall activate an interrupt. Done for groups of 16 lines and for any change of a digital input line.

1 = interrupt enabled 0 = interrupt disabled

If the object is not supported, the device shall behave accordingly to the default value.

Table 70 specifies the object description, and Table 71 specifies the entry description.

Table 70 — Object description

Attribute	Value
INDEX	6106 _h
Name	Interrupt mask input any change 16-bit
Object code	Array
Data type	Unsigned16
Category	Optional

Table 71 — Entry description

Attribute	Value
Sub-Index	00 _h
Description	Number of inputs 16-bit
Access	ro
Entry category	Mandatory
PDO mapping	No
Value range	01 _h to FE _h
Default value	No
Sub-Index	01 _h
Description	Interrupt any change inputs 01 _h to 10 _h
Access	rw
Entry category	Mandatory
PDO mapping	Optional
Value range	Unsigned16
Default value	FFFF _h
Sub-Index	02 _h
Description	Interrupt any change inputs 11 _h to 20 _h
Access	rw
Entry category	Optional
PDO mapping	Optional
Value range	Unsigned16
Default value	FFFF _h
to	
Sub-Index	FE _h
Description	Interrupt any change inputs FD1 _h to FE0 _h
Access	rw
Entry category	Optional
PDO mapping	Optional
Value range	Unsigned16
Default value	FFFF _h

8.2.18 Object 6107_h: Interrupt mask input low-to-high 16-bit

This object determines, which input port lines shall activate an interrupt. Done for groups of 16 lines and for a change from low-to-high of a digital input line. The values shall be in an "OR" connection to the values of 6106_h object (interrupt mask any change 16-bit). If inputs are inverted by 6102_h object (polarity input 16-bit), the positive logical edge shall correspond to negative physical edge.

1 = interrupt enabled 0 = interrupt disabled

If the object is not supported, the device shall behave accordingly to the default value.

Table 72 specifies the object description, and Table 73 specifies the entry description.

Table 72 — Object description

Attribute	Value
INDEX	6107 _h
Name	Interrupt mask input low-to-high 16-bit
Object code	Array
Data type	Unsigned16
Category	Optional

Table 73 — Entry description

Attribute	Value
Sub-Index	00 _h
Description	Number of inputs 16-bit
Access	ro
Entry category	Mandatory
PDO mapping	No
Value range	01 _h to FE _h
Default value	No
to	
Sub-Index	01 _h
Description	Interrupt low-to-high inputs 01 _h to 10 _h
Access	rw
Entry category	Mandatory
PDO mapping	Optional
Value range	Unsigned16
Default value	0000 _h
to	
Sub-Index	02 _h
Description	Interrupt low-to-high inputs 11 _h to 20 _h
Access	rw
Entry category	Optional
PDO mapping	Optional
Value range	Unsigned16
Default value	0000 _h
to	
Sub-Index	FE _h
Description	Interrupt low-to-high inputs FD1 _n to FE0 _h
Access	rw
Entry category	Optional
PDO mapping	Optional
Value range	Unsigned16
Default value	0000 _h

8.2.19 Object 6108_h: Interrupt mask input high-to-low 16-bit

This object determines, which input port lines shall activate an interrupt. Done for groups of 16 lines and for a change from high-to-low of a digital input line. The values shall be in an "OR" connection to the values of 6106_h object (interrupt mask any change 16-bit). If inputs are inverted by 6102_h object (polarity input 16-bit), the negative logical edge shall correspond to positive physical edge.

1 = interrupt enabled 0 = interrupt disabled

If the object is not supported, the device shall behave accordingly to the default value.

Table 74 specifies the object description, and Table 75 specifies the entry description

Table 74 — Object description

Attribute	Value
INDEX	6108 _h
Name	Interrupt mask input high-to-low 16-bit
Object code	Array
Data type	Unsigned16
Category	Optional

Table 75 — Entry description

Attribute	Value
Sub-Index	00 _h
Description	Number of inputs 16-bit
Access	ro
Entry category	Mandatory
PDO mapping	No
Value range	01 _h to FE _h
Default value	No
Sub-Index	01 _h
Description	Interrupt high-to-low inputs 01 _h to 10 _h
Access	rw
Entry category	Mandatory
PDO mapping	Optional
Value range	Unsigned16
Default value	0000 _h
Sub-Index	02 _h
Description	Interrupt high-to-low inputs 11 _h to 20 _h
Access	rw
Entry category	Optional
PDO mapping	Optional
Value range	Unsigned16
Default value	0000 _h

to	
Sub-Index	FE _n
Description	Interrupt high-to-low inputs FD1 _n to FE0 _n
Access	rw
Entry category	Optional
PDO mapping	Optional
Value range	Unsigned16
Default value	0000 _h

8.2.20 Object 6120_h: Read input 32-bit

This object shall read a group of 32 input lines as 32-bit information. A maximum of 254 x 32-bit words is addressable (8128 inputs).

Table 76 specifies the object description, and Table 77 specifies the entry description.

Table 76 — Object description

Attribute	Value
INDEX	6120 _h
Name	Read input 4 Byte
Object code	Array
Data type	Unsigned32
Category	Optional

Table 77 — Entry description

Attribute	Value
Sub-Index	00 _h
Description	Number of inputs 32-bit
Access	ro
Entry category	Mandatory
PDO mapping	No
Value range	01 _h to FE _h
Default value	No
Sub-Index	01 _h
Description	Read inputs 01 _n to 20 _n
Access	ro
Entry category	Mandatory
PDO mapping	Optional
Value range	Unsigned32
Default value	No

Sub-Index	02 _h
Description	Read inputs 21 _h to 40 _h
Access	ro
Entry category	Optional
PDO mapping	Optional
Value range	Unsigned32
Default value	No
to	
Sub-Index	FE _h
Description	Read inputs 1FA0 _h to 1FC0 _h
Access	ro
Entry category	Optional
PDO mapping	Optional
Value range	Unsigned32
Default value	No

8.2.21 Object 6122_h: Polarity input 32-bit

This object shall define the polarity for a group of 32 input lines. Inputs can be inverted individually.

1 = input inverted 0 = input not inverted

If the object is not supported the device shall behave accordingly to the default value.

Table 78 specifies the object description, and Table 79 specifies the entry description.

Table 78 — Object description

Attribute	Value
INDEX	6122 _h
Name	Polarity input 32-bit
Object code	Array
Data type	Unsigned32
Category	Optional

Table 79 — Entry description

Attribute	Value
Sub-Index	00 _h
Description	Number of inputs 32-bit
Access	ro
PDO mapping	No
Value range	01 _h to FE _h
Default value	0000 0000 _h

Sub-Index	01 _h
Description	Polarity inputs 01 _h to 20 _h
Access	rw
Entry category	Mandatory
PDO mapping	No
Value range	Unsigned32
Default value	0000 0000 _h
to	
Sub-Index	02 _h
Description	Polarity inputs 21 _h to 40 _h
Access	rw
Entry category	Optional
PDO mapping	No
Value range	Unsigned32
Default value	0000 0000 _h
to	
Sub-Index	FE _h
Description	Polarity inputs 1FA0 _h to 1FC0 _h
Access	rw
Entry category	Optional
PDO mapping	Optional
Value range	Unsigned32
Default value	0000 0000 _h

8.2.22 Object 6123_h: Filter constant input 32-bit

This object shall enable and disable an additional configurable filter constant. If the object is not supported, the device shall behave accordingly to the default value. The type of the filter constant and the configuration of the filter constant are manufacturer-specific.

1 = enabled 0 = disabled

Table 80 specifies the object description, and Table 81 specifies the entry description.

Table 80 — Object description

Attribute	Value
INDEX	6123 _h
Name	Filter constant input 32-bit
Object code	Array
Data type	Unsigned32
Category	Optional

Table 81 — Entry description

Attribute	Value
Sub-Index	00 _h
Description	Number of inputs 32-bit
Access	ro
Entry category	Mandatory
PDO mapping	No
Value range	01 _h to FE _h
Default value	No
Sub-Index	01 _h
Description	Filter constant inputs 01 _h to 20 _h
Access	rw
Entry category	Mandatory
PDO mapping	Optional
Value range	Unsigned32
Default value	0000 0000 _h
Sub-Index	02 _h
Description	Filter constant inputs 21 _h to 40 _h
Access	rw
Entry category	Optional
PDO mapping	Optional
Value range	Unsigned32
Default value	0000 0000 _h
to	
Sub-Index	FE _h
Description	Filter constant inputs 1FA1 _h to 1FC0 _h
Access	rw
Entry category	Optional
PDO mapping	Optional
Value range	Unsigned32
Default value	0000 0000 _h

8.2.23 Object 6126_h: Interrupt mask input any change 32-bit

This object determines which input port lines shall activate an interrupt. Done for groups of 32 lines and for any change of a digital input line.

1 = interrupt enabled 0 = interrupt disabled

If the object is not supported, the device shall behave accordingly to the default value.

Table 82 specifies the object description, and Table 83 specifies the entry description.

Table 82 — Object description

Attribute	Value
INDEX	6126 _h
Name	Interrupt mask input any change 32-bit
Object code	Array
Data type	Unsigned32
Category	Optional

Table 83 — Entry description

Attribute	Value
Sub-Index	00 _h
Description	Number of inputs 32-bit
Access	ro
Entry category	Mandatory
PDO mapping	No
Value range	01 _h to FE _h
Default value	No
Sub-Index	01 _h
Description	Interrupt any change input 01 _h to 20 _h
Access	rw
Entry category	Mandatory
PDO mapping	Optional
Value range	Unsigned32
Default value	FFFF FFFF _h
Sub-Index	02 _h
Description	Interrupt any change input 21 _h to 40 _h
Access	rw
Entry category	Optional
PDO mapping	Optional
Value range	Unsigned32
Default value	FFFF FFFF _h
to	
Sub-Index	FE _h
Description	Interrupt any change input 1FA1 _h to 1FC0 _h
Access	rw
Entry category	Optional
PDO mapping	Optional
Value range	Unsigned32
Default value	FFFF FFFF _h

8.2.24 Object 6127_h: Interrupt mask input low-to-high 32-bit

This object determines, which input port lines shall activate an interrupt. Done for groups of 32 lines and for a change from low-to-high of a digital input line. The values shall be in an "OR" connection to the values of 6126_h object (interrupt mask any change 32-bit). If inputs are inverted by 6122_h object (polarity input 32-bit), the positive logical edge shall correspond to negative physical edge.

1 = interrupt enabled 0 = interrupt disabled

If the object is not supported, the device shall behave accordingly to the default value.

Table 84 specifies the object description, and Table 85 specifies the entry description.

Table 84 — Object description

Attribute	Value
INDEX	6127 _h
Name	Interrupt mask input low-to-high 32-bit
Object code	Array
Data type	Unsigned32
Category	Optional

Table 85 — Entry description

Attribute	Value
Sub-Index	00 _h
Description	Number of inputs 32-bit
Access	ro
Entry category	Mandatory
PDO mapping	No
Value range	01 _h to FE _h
Default value	No
Sub-Index	01 _h
Description	Interrupt low-to-high input 01 _h to 20 _h
Access	rw
Entry category	Mandatory
PDO mapping	Optional
Value range	Unsigned32
Default value	0000 0000 _h
Sub-Index	02 _h
Description	Interrupt low-to-high input 21 _h to 40 _h
Access	rw
Entry category	Optional
PDO mapping	Optional
Value range	Unsigned32
Default value	0000 0000 _h

to	
Sub-Index	FE _n
Description	Interrupt low-to-high input 1FA1 _n to 1FC0 _n
Access	rw
Entry category	Optional
PDO mapping	Optional
Value range	Unsigned32
Default value	0000 0000 _n

8.2.25 Object 6128_n: Interrupt mask input high-to-low 32-bit

This object determines, which input port lines shall activate an interrupt. Done for groups of 32 lines and for a change from high-to-low of a digital input line. The values shall be in an "OR" connection to the values of 6126_n object (interrupt mask any change 32-bit). If inputs are inverted by 6122_n object (polarity input 32-bit), the negative logical edge shall correspond to positive physical edge.

1 = interrupt enabled 0 = interrupt disabled

If the object is not supported, the device shall behave accordingly to the default value.

Table 86 specifies the object description, and Table 87 specifies the entry description.

Table 86 — Object description

Attribute	Value
INDEX	6128 _n
Name	Interrupt mask input high-to-low 32-bit
Object code	Array
Data type	Unsigned32
Category	Optional

Table 87 — Entry description

Attribute	Value
Sub-Index	00 _n
Description	Number of inputs 32-bit
Access	ro
Entry category	Mandatory
PDO mapping	No
Value range	01 _n to FE _n
Default value	No
Sub-Index	01 _n
Description	Interrupt high-to-low input 01 _n to 20 _n
Access	rw
Entry category	Mandatory
PDO mapping	Optional
Value range	Unsigned32
Default value	0000 0000 _n

Sub-Index	02 _h
Description	Interrupt high-to-low input 21 _n to 40 _n
Access	rw
Entry category	Optional
PDO mapping	Optional
Value range	Unsigned32
Default value	0000 0000 _h
to	
Sub-Index	FE _h
Description	Interrupt high-to-low input 1FA1 _n to 1FC0 _n
Access	rw
Entry category	Optional
PDO mapping	Optional
Value range	Unsigned32
Default Value	0000 0000 _h

8.3 Digital output module

8.3.1 Object 6200_h: Write output 8-bit

This object shall set a group of 8 output lines as a byte of information. A maximum of 254 x 8 bit output blocks is addressable.

Table 88 specifies the object description, and Table 89 specifies the entry description.

Table 88 — Object description

Attribute	Value
INDEX	6200 _h
Name	Write output 8-bit
Object code	Array
Data type	Unsigned8
Category	Conditional: Device with digital outputs

Table 89 — Entry description

Attribute	Value
Sub-Index	00 _h
Description	Number of outputs 8-bit
Access	ro
Entry category	Mandatory
PDO mapping	No
Value range	01 _h to FE _h
Default value	No

Sub-Index	01 _h
Description	Write output 01 _h to 08 _h
Access	rw
Entry category	Mandatory
PDO mapping	Default
Value range	Unsigned8
Default value	00 _h
to	
Sub-Index	02 _h
Description	Write output 09 _h to 10 _h
Access	rw
Entry category	Optional
PDO mapping	Default
Value range	Unsigned8
Default value	00 _h
to	
Sub-Index	08 _h
Description	Write output 39 _h to 40 _h
Access	rw
Entry category	Optional
PDO mapping	Default
Value range	Unsigned8
Default value	00 _h
to	
Sub-Index	09 _h
Description	Write output 41 _h to 48 _h
Access	rw
Entry category	Optional
PDO mapping	Optional
Value range	Unsigned8
Default value	00 _h
to	
Sub-Index	FE _h
Description	Write output 7E9 _h to 7F0 _h
Access	rw
Entry category	Optional
PDO mapping	Optional
Value range	Unsigned8
Default value	00 _h

8.3.2 Object 6202_h: Change polarity output 8-bit

This object shall define the polarity of a group of 8 output lines. Output polarity can be inverted individually.

1 = output inverted

0 = output not inverted

If the object is not supported, the device shall behave accordingly to the default value.

Table 90 specifies the object description, and Table 91 specifies the entry description.

Table 90 — Object description

Attribute	Value
INDEX	6202 _h
Name	Change polarity output 8-bit
Object code	Array
Data type	Unsigned8
Category	Optional

Table 91 — Entry description

Attribute	Value
Sub-Index	00 _h
Description	Number of outputs 8-bit
Access	ro
Entry category	Mandatory
PDO mapping	No
Value range	01 _h to FE _h
Default value	No
Sub-Index	01 _h
Description	Change polarity output 01 _h to 08 _h
Access	rw
Entry category	Mandatory
PDO mapping	Optional
Value range	Unsigned8
Default value	00 _h
Sub-Index	02 _h
Description	Change polarity output 09 _h to 10 _h
Access	rw
Entry category	Optional
PDO mapping	Optional
Value range	Unsigned8
Default value	00 _h
to	
Sub-Index	FE _h
Description	Change polarity output 7E9 _h to 7F0 _h
Access	rw
Entry category	Optional
PDO mapping	Optional
Value range	Unsigned8
Default value	00 _h

8.3.3 Object 6206_h: Error mode output 8-bit

This object indicates, whether an output is set to a pre-defined error value (see 6207_h object) in case of an internal device failure or a 'Stop Remote Node' indication.

1 = output value shall take the pre-defined condition specified in 6207_h object

0 = output value shall be kept if an error occurs

If the object is not supported, the device shall behave accordingly to the default value.

Table 92 specifies the object description, and Table 93 specifies the entry description.

Table 92 — Object description

Attribute	Value
INDEX	6206 _h
Name	Error mode output 8-bit
Object code	Array
Data type	Unsigned8
Category	Optional

Table 93 — Entry description

Attribute	Value
Sub-Index	00 _h
Description	Number of outputs 8-bit
Access	ro
Entry category	Mandatory
PDO mapping	No
Value range	01 _h to FE _h
Default value	No
Sub-Index	01 _h
Description	Error mode output 01 _h to 08 _h
Access	rw
Entry category	Mandatory
PDO mapping	Optional
Value range	Unsigned8
Default value	FF _h
Sub-Index	02 _h
Description	Error mode output 09 _h to 10 _h
Access	rw
Entry category	Optional
PDO mapping	Optional
Value range	Unsigned8
Default value	FF _h
to	

Sub-Index	FE _h
Description	Error mode output 7E9 _h to 7F0 _h
Access	rw
Entry category	Optional
PDO mapping	Optional
Value range	Unsigned8
Default value	FF _h

8.3.4 Object 6207_h: Error value output 8-bit

On condition that the corresponding Error mode is active, device failures (see chapter 5.2) shall set the outputs to the value configured by this object.

0 = output shall be set to '0' in case of fault, if 6206_h object is enabled

1 = output shall be set to '1' in case of fault, if 6206_h object is enabled

If the object is not supported, the device shall behave accordingly to the default value.

Table 94 specifies the object description, and Table 95 specifies the entry description.

Table 94 — Object description

Attribute	Value
INDEX	6207 _h
Name	Error value output 8-bit
Object code	Array
Data type	Unsigned8
Category	Optional

Table 95 — Entry description

Attribute	Value
Sub-Index	00 _h
Description	Number of outputs 8-bit
Access	ro
Entry category	Mandatory
PDO mapping	No
Value range	01 _h to FE _h
Default value	No
Sub-Index	01 _h
Description	Error value output 01 _h to 08 _h
Access	rw
Entry category	Mandatory
PDO mapping	Optional
Value range	Unsigned8
Default value	00 _h

Sub-Index	02 _h
Description	Error value output 09 _h to 10 _h
Access	rw
Entry category	Optional
PDO mapping	Optional
Value range	Unsigned8
Default value	00 _h
to	
Sub-Index	FE _h
Description	Error value output 7E9 _h to 7F0 _h
Access	rw
Entry category	Optional
PDO mapping	Optional
Value range	Unsigned8
Default value	00 _h

8.3.5 Object 6208_h: Filter mask output 8-bit

This object defines an additional configurable output filter mask for a group of 8 outputs.

1 = output shall be set to the received output value

0 = don't care, the received output value is neglected for the appropriated output channel, the old output value shall be kept.

If the object is not supported, the device shall behave accordingly to the default value.

Table 96 specifies the object description, and Table 97 specifies the entry description.

Table 96 — Object description

Attribute	Value
INDEX	6208 _h
Name	Filter mask output 8-bit
Object code	Array
Data type	Unsigned8
Category	Optional

Table 97 — Entry description

Attribute	Value
Sub-Index	00 _h
Description	Number of outputs 8-bit
Access	ro
Entry category	Mandatory
PDO mapping	No
Value range	01 _h to FE _h
Default value	No

Sub-Index	01 _h
Description	Filter mask output 01 _h to 08 _h
Access	rw
Entry category	Mandatory
PDO mapping	Optional
Value range	Unsigned8
Default value	FF _h
to	
Sub-Index	02 _h
Description	Filter mask output 09 _h to 10 _h
Access	rw
Entry category	Optional
PDO mapping	Optional
Value range	Unsigned8
Default value	FF _h
to	
Sub-Index	FE _h
Description	Filter mask output 7E9 _h to 7F0 _h
Access	rw
Entry category	Optional
PDO mapping	Optional
Value range	Unsigned8
Default value	FF _h

8.3.6 Object 6220_h to 6227_h: Write output bit 1 to 128 to write output bit 897 to 1024

These objects shall set single output lines information. A maximum of 128 outputs is addressable at one index. The 6220_h object shall address output lines 1 to 128, the 6221_h object shall address output lines 129 to 256, etc.

Table 98 specifies the object description, and Table 99 specifies the entry description.

Table 98 — Object description

Attribute	Value
Name	Write output bit 01 _h to 80 _h
Object code	Array
Data type	Boolean
Category	Optional

Table 99 — Entry description

Attribute	Value
Description	Number of outputs 1-bit
Access	ro
Entry category	Mandatory
PDO mapping	No
Value range	01 _h to 80 _h
Default value	No

Sub-Index	01 _h
Description	Write output 01 _h
Access	rw
Entry category	Mandatory
PDO mapping	Optional
Value range	Boolean
Default value	FALSE
Sub-Index	02 _h
Description	Write output 02 _h
Access	rw
Entry category	Optional
PDO mapping	Optional
Value range	Boolean
Default value	FALSE
to	
Sub-Index	80 _h
Description	Write output 80 _h
Access	rw
Entry category	Optional
PDO mapping	Optional
Value range	Boolean
Default value	FALSE

8.3.7 Object 6240_h to 6247_h: Change polarity output bit 1 to 128 to change polarity output bit 897 to 1024

These objects shall set the polarity of single output lines. A maximum of 128 outputs is addressable at one index. The 6240_h object shall address output lines 1 to 128, the 6241_h object shall address output lines 129 to 256, etc.

TRUE = output inverted

FALSE = output not inverted

If these objects are not supported the device shall behave accordingly to the default value.

Table 100 specifies the object description, and Table 101 specifies the entry description.

Table 100 — Object description

Attribute	Value
INDEX	6240 _h
Name	Change polarity output bit 01 _h to 80 _h
Object code	Array
Data type	Boolean
Category	Optional

Table 101 — Entry description

Attribute	Value
Sub-Index	00 _h
Description	Number of outputs 1-bit
Access	ro
Entry category	Mandatory
PDO mapping	No
Value range	01 _h to 80 _h
Default value	No
Sub-Index	01 _h
Description	Change polarity output 01 _h
Access	rw
Entry category	Mandatory
PDO mapping	Optional
Value range	Boolean
Default value	FALSE
Sub-Index	02 _h
Description	Change polarity output 02 _h
Access	rw
Entry category	Optional
PDO mapping	Optional
Value range	Boolean
Default value	FALSE
to	
Sub-Index	80 _h
Description	Change polarity output 80 _h
Access	rw
Entry category	Optional
PDO mapping	Optional
Value range	Boolean
Default value	FALSE

8.3.8 Object 6250_h to 6257_h: Error mode output lines 1 to 128 to error mode output lines 897 to 1024

These objects indicate, whether an output is set to a pre-defined error value (see 6260_h to 6267_h objects) in case of an internal device failure a 'Stop remote node' indication. A maximum of 128 outputs is addressable at one index. The 6250_h object shall address output lines 1 to 128, the 6251_h object shall address output lines 129 to 256, etc.

TRUE = output value shall take the pre-defined condition as specified in 6260_h to 6267_h objects

FALSE = output value shall be kept if an error occurs

If the object is not supported, the device shall behave accordingly to the default value.

Table 102 specifies the object description, and Table 103 specifies the entry description.

Table 102 — Object description

Attribute	Value
INDEX	6250 _h
Name	Error mode output lines 01 _h to 80 _h
Object code	Array
Data type	Boolean
Category	Optional

Table 103 — Entry description

Attribute	Value
Sub-Index	00 _h
Description	Number of outputs 1-bit
Access	ro
Entry category	Mandatory
PDO mapping	No
Value range	01 _h to 80 _h
Default value	No
Sub-Index	01 _h
Description	Error mode output 01 _h
Access	rw
Entry category	Mandatory
PDO mapping	Optional
Value range	Boolean
Default value	TRUE
Sub-Index	02 _h
Description	Error mode output 02 _h
Access	rw
Entry category	Optional
PDO mapping	Optional
Value range	Boolean
Default value	TRUE
to	
Sub-Index	80 _h
Description	Error mode output 80 _h
Access	rw
Entry category	Optional
PDO mapping	Optional
Value range	Boolean
Default value	TRUE

8.3.9 Object 6260_h to 6267_h: Error value output bit 1 to 128 to error value output bit 897 to 1024

On condition that the corresponding error mode is active, device failures (see chapter 5.2) shall set the outputs to the value configured by this object. A maximum of 128 outputs is addressable at one index. The 6260_h object shall address output lines 1 to 128, the 6261_h object shall address output lines 129 to 256, etc.

FALSE = output shall be set to '0' in case of fault, if the corresponding object (6250_h to 6257_h) is enabled

TRUE = output shall be set to '1' in case of fault, if the corresponding object (6250_h to 6257_h) is enabled

If the object is not supported, the device shall behave accordingly to the default value.

Table 104 specifies the object description, and Table 105 specifies the entry description.

Table 104 — Object description

Attribute	Value
INDEX	6260 _h
Name	Error value output bit 01 _h to 80 _h
Object code	Array
Data type	Boolean
Category	Optional

Table 105 — Entry description

Attribute	Value
Sub-Index	00 _h
Description	Number of outputs 1-bit
Access	ro
Entry category	Mandatory
PDO mapping	No
Value range	01 _h to 80 _h
Default value	No
Default value	No
Sub-Index	01 _h
Description	Error value output 01 _h
Access	rw
Entry category	Mandatory
PDO mapping	Optional
Value range	Boolean
Default value	FALSE

Sub-Index	02 _h
Description	Error value output 02 _h
Access	rw
Entry category	Optional
PDO mapping	Optional
Value range	Boolean
Default value	FALSE
to	
Sub-Index	80 _h
Description	Error value output 80 _h
Access	rw
Entry category	Optional
PDO mapping	Optional
Value range	Boolean
Default value	FALSE

8.3.10 Object 6270_h to 6277_h: Filter mask output bit 1 to 128 to filter mask output bit 897 to 1024

This object defines an additional configurable output filter mask for a single output.

TRUE = output shall set to the received output value

FALSE = don't care the received output value is neglected for the appropriated output channel, the old output value shall be kept

A maximum of 128 outputs is addressable at one index. The 6270_h object shall address output lines 1 to 128, the 6271_h object shall address output lines 129 to 256, etc.

If the object is not supported, the device shall behave accordingly to the default value.

Table 106 specifies the object description, and Table 107 specifies the entry description.

Table 106 — Object description

Attribute	Value
INDEX	6270 _h
Name	Filter mask output bit 01 _h to 80 _h
Object code	Array
Data type	Boolean
Category	Optional

Table 107 — Entry description

Attribute	Value
Sub-Index	00 _h
Description	Number of outputs 1-bit
Access	ro
Entry category	Mandatory
PDO mapping	No
Value range	01 _h to 80 _h
Default value	No

Sub-Index	01 _h
Description	Filter mask output 01 _h
Access	rw
Entry category	Mandatory
PDO mapping	Optional
Value range	Boolean
Default value	TRUE
Sub-Index	02 _h
Description	Filter mask output 02 _h
Data type	Boolean
Access	rw
Entry category	Optional
PDO mapping	Optional
Value range	Boolean
Default value	TRUE
to	
Sub-Index	80 _h
Description	Filter mask output 80 _h
Data type	Boolean
Access	rw
Entry category	Optional
PDO mapping	Optional
Value range	Boolean
Default value	TRUE

8.3.11 Object 6300_h: Write output 16-bit

This object shall set a group of 16 output lines as 2-byte information. A maximum of 255 x 16-bit words is addressable (4080 outputs).

Table 108 specifies the object description, and Table 109 specifies the entry description.

Table 108 — Object description

Attribute	Value
INDEX	6300 _h
Name	Write output 16-bit
Object code	Array
Data type	Unsigned16
Category	Optional

Table 109 — Entry description

Attribute	Value
Sub-Index	00 _h
Description	Number of outputs 16-bit
Access	ro
Entry category	Mandatory
PDO mapping	No
Value range	01 _h to FE _h
Default value	No
Sub-Index	01 _h
Description	Write output 01 _h to 10 _h
Access	rw
Entry category	Mandatory
PDO mapping	Optional
Value range	Unsigned16
Default value	0000 _h
Sub-Index	02 _h
Description	Write output 11 _h to 20 _h
Access	rw
Entry category	Optional
PDO mapping	Optional
Value range	Unsigned16
Default value	0000 _h
to	
Sub-Index	FE _h
Description	Write output FE0 _h to FF0 _h
Access	rw
Entry category	Optional
PDO mapping	Optional
Value range	Unsigned16
Default value	0000 _h

8.3.12 Object 6302_h: Change polarity output 16-bit

This object shall define the polarity for a group of 16 output lines. Output polarity can be inverted individually.

1 = enabled 0 = disabled

If the object is not supported the device shall behave accordingly to the default value.

Table 110 specifies the object description, and Table 111 specifies the entry description.

Table 110 — Object description

Attribute	Value
INDEX	6302 _h
Name	Change polarity output 16-bit
Object code	Array
Data type	Unsigned16
Category	Optional

Table 111 — Entry description

Attribute	Value
Sub-Index	00 _h
Description	Number of outputs 16-bit
Access	ro
Entry category	Mandatory
PDO mapping	No
Value range	01 _h to FE _h
Default value	No
Sub-Index	01 _h
Description	Polarity output 01 _h to 10 _h
Data type	Unsigned16
Access	rw
Entry category	Mandatory
PDO mapping	No
Value range	Unsigned16
Default value	0000 _h
Sub-Index	02 _h
Description	Polarity output 11 _h to 20 _h
Access	rw
Entry category	Optional
PDO mapping	Optional
Value range	Unsigned16
Default value	0000 _h
to	
Sub-Index	FE _h
Description	Polarity output FE0 _h to FF0 _h
Access	rw
Entry category	Optional
PDO mapping	Optional
Value range	Unsigned16
Default value	0000 _h

8.3.13 Object 6306_h: Error mode output 16-bit

These objects indicate, whether an output is set to a pre-defined error value (see 6307_h object) in case of an internal device failure a 'Stop Remote Node' indication.

1 = output value shall take the pre-defined condition as specified in 6307_h object

0 = output value shall be kept if an error occurs

If the object is not supported, the device shall behave accordingly to the default value.

Table 112 specifies the object description, and Table 113 specifies the entry description.

Table 112 — Object description

Attribute	Value
INDEX	6306 _h
Name	Error mode output 16-bit
Object code	Array
Data type	Unsigned16
Category	Optional

Table 113 — Entry description

Attribute	Value
Sub-Index	00 _h
Description	Number of outputs 16-bit
Access	ro
Entry category	Mandatory
PDO mapping	No
Value range	01 _h to FE _h
Default value	No
Sub-Index	01 _h
Description	Error mode output 01 _h to 10 _h
Access	rw
Entry category	Mandatory
PDO mapping	Optional
Value range	Unsigned16
Default value	FFFF _h
Sub-Index	02 _h
Description	Error mode output 11 _h to 20 _h
Access	rw
Entry category	Optional
PDO mapping	Optional
Value range	Unsigned16
Default value	FFFF _h
to	

Sub-Index	FE _n
Description	Error mode output FE0 _n to FF0 _n
Access	rw
Entry category	Optional
PDO mapping	Optional
Value range	Unsigned16
Default value	FFFF _n

8.3.14 Object 6307_n: Error value output 16-bit

On condition that the corresponding error mode is active, device failures (see chapter 5.2) shall set the outputs to the value configured by this object.

0 = output shall be set to '0' in case of fault, if 6306h object is enabled

1 = output shall be set to '1' in case of fault, if 6306h object is enabled

If the object is not supported, the device shall behave accordingly to the default value.

Table 114 specifies the object description, and Table 115 specifies the entry description.

Table 114 — Object description

Attribute	Value
INDEX	6307 _n
Name	Error value output 16-bit
Object code	Array
Data type	Unsigned16
Category	Optional

Table 115 — Entry description

Attribute	Value
Sub-Index	00 _n
Description	Number of outputs 16-bit
Access	ro
Entry category	Mandatory
PDO mapping	No
Value range	01 _n to FE _n
Default value	No
Sub-Index	01 _n
Description	Error value output 01 _n to 10 _n
Access	rw
Entry category	Mandatory
PDO mapping	Optional
Value range	Unsigned16
Default value	0000 _n

Sub-Index	02 _h
Description	Error value output 11 _h to 20 _h
Access	rw
Entry category	Optional
PDO mapping	Optional
Value range	Unsigned16
Default value	0000 _h
to	
Sub-Index	FE _h
Description	Error value output FE0 _h to FF0 _h
Access	rw
Entry category	Optional
PDO mapping	Optional
Value range	Unsigned16
Default value	0000 _h

8.3.15 Object 6308_h: Filter mask output 16-bit

This object defines an additional configurable output filter mask for a group of 16 outputs.

1 = output is shall set to the received output value

0 = don't care, the received output value is neglected for the appropriated output channel, the old output value shall be kept.

If the object is not supported, the device shall behave accordingly to the default value.

Table 116 specifies the object description, and Table 117 specifies the entry description.

Table 116 — Object description

Attribute	Value
INDEX	6308 _h
Name	Filter mask output 16-bit
Object code	Array
Data type	Unsigned16
Category	Optional

Table 117 —Entry description

Attribute	Value
Sub-Index	00 _h
Description	Number of outputs 16-bit
Access	ro
Entry category	Mandatory
PDO mapping	No
Value range	01 _h to FE _h
Default value	No

Sub-Index	01 _h
Description	Filter mask output 01 _h to 10 _h
Access	rw
Entry category	Optional
PDO mapping	Optional
Value range	Unsigned16
Default value	FFFF _h
to	
Sub-Index	02 _h
Description	Filter mask output 11 _h to 20 _h
Access	rw
Entry category	Optional
PDO mapping	Optional
Value range	Unsigned16
Default value	FFFF
to	
Sub-Index	FE _h
Description	Filter mask output FE0 _h to FF0 _h
Access	rw
Entry category	Optional
PDO mapping	Optional
Value range	Unsigned16
Default value	FFFF _h

8.3.16 Object 6320_h: Write output 32-bit

This object shall set a group of 32 output lines as 4-Byte information. A maximum of 255 x 32-bit words is addressable (8160 outputs).

Table 118 specifies the object description, and Table 119 specifies the entry description.

Table 118 — Object description

Attribute	Value
INDEX	6320 _h
Name	Write output 32-bit
Object code	Array
Data type	Unsigned32
Category	Optional

Table 119 — Entry description

Attribute	Value
Sub-Index	00 _h
Description	Number of outputs 32-bit
Access	ro
Entry category	Mandatory
PDO mapping	No
Value range	01 _h to FE _h
Default value	No
Sub-Index	01 _h
Description	Write output 01 _h to 20 _h
Access	rw
Entry category	Mandatory
PDO mapping	Optional
Value range	Unsigned32
Default value	0000 0000 _h
Sub-Index	02 _h
Description	Write output 21 _h to 40 _h
Data type	Unsigned32
Access	rw
Entry category	Optional
PDO mapping	Optional
Value range	Unsigned32
Default value	0000 0000 _h
to	
Sub-Index	FE _h
Description	Write output 1FC0 _h to 1FE0 _h
Data type	Unsigned32
Access	rw
Entry category	Optional
PDO mapping	Optional
Value range	Unsigned32
Default value	0000 0000 _h

8.3.17 Object 6322_h: Change polarity output 32-bit

This object shall define the polarity for a group of 32 output lines. Output polarity can be inverted individually.

1 = enabled 0 = disabled

If the object is not supported the device shall behave accordingly to the default value.

Table 120 specifies the object description, and Table 121 specifies the entry description.

Table 120 — Object description

Attribute	Value
INDEX	6322 _h
Name	Change polarity output 32-bit
Object code	Array
Data type	Unsigned32
Category	Optional

Table 121 — Entry description

Attribute	Value
Sub-Index	00 _h
Description	Number of outputs 32-bit
Access	ro
Entry category	Mandatory
PDO mapping	No
Value range	01 _h to FE _h
Default value	No
Sub-Index	01 _h
Description	Polarity output 01 _h to 20 _h
Access	rw
Entry category	Mandatory
PDO mapping	No
Value range	Unsigned32
Default value	0000 0000 _h
Sub-Index	02 _h
Description	Polarity output 21 _h to 40 _h
Access	rw
Entry category	Optional
PDO mapping	Optional
Value range	Unsigned32
Default value	0000 0000 _h
to	
Sub-Index	FE _h
Description	Polarity output 1FC0 _h to 1FE0 _h
Access	rw
Entry category	Optional
PDO mapping	Optional
Value range	Unsigned32
Default value	0000 0000 _h

8.3.18 Object 6326_h: Error mode output 32-bit

These objects indicate, whether an output is set to a pre-defined error value (see also 6327_h object) in case of an internal device failure a 'Stop Remote Node' indication.

1 = output value shall take the pre-defined condition as specified in 6327_h object

0 = output value shall be kept if an error occurs

If the object is not supported, the device shall behave accordingly to the default value.

Table 122 specifies the object description, and Table 123 specifies the entry description.

Table 122 — Object description

Attribute	Value
INDEX	6326 _h
Name	Error mode output 32-bit
Object code	Array
Data type	Unsigned32
Category	Optional

Table 123 — Entry description

Attribute	Value
Sub-Index	00 _h
Description	Number of outputs 32-bit
Access	ro
Entry category	Mandatory
PDO mapping	No
Value range	01 _h to FE _h
Default value	No
Sub-Index	01 _h
Description	Error mode output 01 _h to 20 _h
Access	rw
Entry category	Mandatory
PDO mapping	Optional
Value range	Unsigned32
Default value	FFFF FFFF _h
Sub-Index	02 _h
Description	Error mode output 21 _h to 40 _h
Access	rw
Entry category	Optional
PDO mapping	Optional
Value range	Unsigned32
Default value	FFFF FFFF _h
to	

Sub-Index	FE _h
Description	Error mode output 1FC0 _h to 1FE0 _h
Access	rw
Entry category	Optional
PDO mapping	Optional
Value range	Unsigned32
Default value	FFFF FFFF _h

8.3.19 Object 6327_h: Error value output 32-bit

On condition that the corresponding error mode is active, device failures (see chapter 5.2) shall set the outputs to the value configured by this object.

0 = output shall be set to '0' in case of fault, if 6326_h object is enabled

1 = output shall be set to '1' in case of fault, if 6326_h object is enabled

If the object is not supported, the device shall behave accordingly to the default value.

Table 124 specifies the object description, and Table 125 specifies the entry description.

Table 124 — Object description

Attribute	Value
INDEX	6327 _h
Name	Error value output 32-bit
Object code	Array
Data type	Unsigned32
Category	Optional

Table 125 — Entry description

Attribute	Value
Sub-Index	00 _h
Description	Number of outputs 32-bit
Access	ro
Entry category	Mandatory
PDO mapping	No
Value range	01 _h to FE _h
Default value	No
Sub-Index	01 _h
Description	Error value output 01 _h to 20 _h
Access	rw
Entry category	Mandatory
PDO mapping	Optional
Value range	Unsigned32
Default value	0000 0000 _h

Sub-Index	02 _h
Description	Error value output 21 _h to 40 _h
Access	rw
Entry category	Optional
PDO mapping	Optional
Value range	Unsigned32
Default value	0000 0000 _h
to	
Sub-Index	FE _h
Description	Error value output 1FC0 _h to 1FE0 _h
Access	rw
Entry category	Optional
PDO mapping	Optional
Value range	Unsigned32
Default value	0000 0000 _h

8.3.20 Object 6328_h: Filter mask output 32-bit

This object defines an additional configurable output filter mask for a group of 32 outputs.

1 = output shall be set to the received output value

0 = don't care the received output value is neglected for the appropriated output channel, the old output value shall be kept.

If the object is not supported, the device shall behave accordingly to the default value.

Table 126 specifies the object description, and Table 127 specifies the entry description.

Table 126 — Object description

Attribute	Value
INDEX	6328 _h
Name	Filter mask output 32-bit
Object code	Array
Data type	Unsigned32
Category	Optional

Table 127 — Entry description

Attribute	Value
Sub-Index	00 _h
Description	Number of outputs 32-bit
Access	ro
Entry category	Mandatory
PDO mapping	No
Value range	01 _h to FE _h
Default value	No

Sub-Index	01 _h
Description	Filter mask output 01 _h to 20 _h
Access	rw
Entry category	Mandatory
PDO mapping	Optional
Value range	Unsigned32
Default value	FFFF FFFF _h
to	
Sub-Index	02 _h
Description	Filter mask output 21 _h to 40 _h
Data type	Unsigned32
Access	rw
Entry category	Optional
PDO mapping	Optional
Value range	Unsigned32
Default value	FFFF FFFF _h
to	
Sub-Index	FE _h
Description	Filter mask output 1FC0 _h to 1FE0 _h
Data type	Unsigned32
Access	rw
Entry category	Optional
PDO mapping	Optional
Value range	Unsigned32
Default value	FFFF FFFF _h

8.4 Analogue input module

8.4.1 Object 6400_h: Read analogue input 8-bit

This object shall read the value of the input channel 'n'. Value is 8-bit or less in size. The value shall be always left adjusted. The remaining bits at the right side of the LSB shall be set to zero.

Table 128 specifies the object description, and Table 129 specifies the entry description.

Table 128 — Object description

Attribute	Value
INDEX	6400 _h
Name	Read analogue input 8-bit
Object code	Array
Data type	Integer8
Category	Optional

Table 129 — Entry description

Attribute	Value
Sub-Index	00 _h
Description	Number of analogue inputs 8-bit
Access	ro
Entry category	Mandatory
PDO mapping	No
Value range	01 _h to FE _h
Default value	No
Sub-Index	01 _h
Description	Analogue input 01 _h
Access	ro
Entry category	Mandatory
PDO mapping	Optional
Value range	Integer8
Default value	No
Sub-Index	02 _h
Description	Analogue input 02 _h
Access	ro
Entry category	Optional
PDO mapping	Optional
Value range	Integer8
Default value	No
to	
Sub-Index	FE _h
Description	Analogue input FE _h
Access	ro
Entry category	Optional
PDO mapping	Optional
Value range	Integer8
Default value	No

8.4.2 Object 6401_h: Read analogue input 16-bit

This object shall read the value of the input channel 'n'. Value is 16-bit wide or less. The value shall be always left adjusted. The remaining bits at the right side of the LSB shall be set to zero.

Table 130 specifies the object description, and Table 131 specifies the entry description.

Table 130 — Object description

Attribute	Value
INDEX	6401 _h
Name	Read analogue input 16-bit
Object code	Array
Data type	Integer16
Category	Conditional: Device with analog input

Table 131 — Entry description

Attribute	Value
Sub-Index	00 _h
Description	Number of analogue inputs 16-bit
Access	ro
Entry category	Mandatory
PDO mapping	No
Value range	01 _h to FE _h
Default value	No
to	
Sub-Index	01 _h
Description	Analogue input 01 _h
Access	ro
Entry category	Mandatory
PDO mapping	Default
Value range	Integer16
Default value	No
to	
Sub-Index	02 _h
Description	Analogue input 02 _h
Access	ro
Entry category	Optional
PDO mapping	Default
Value range	Integer16
Default value	No
to	
Sub-Index	0C _h
Description	Analogue input 0C _h
Access	ro
Entry category	Optional
PDO mapping	Default
Value range	Integer
Default value	No
to	

Sub-Index	0D _n
Description	Analogue input 0D _n
Access	ro
Entry category	Optional
PDO mapping	Optional
Value range	Integer16
Default value	No
to	
Sub-Index	FE _n
Description	Analogue input FE _n
Access	ro
Entry category	Optional
PDO mapping	Optional
Value range	Integer16
Default value	No

8.4.3 Object 6402_h: Read analogue input 32-bit

This object shall read the value of the input channel 'n'. Value is 32-bit wide or less. The value shall be always left adjusted. The remaining bits at the right side of the LSB shall be set to zero.

Table 132 specifies the object description, and Table 133 specifies the entry description

Table 132 — Object description

Attribute	Value
INDEX	6402 _h
Name	Read analogue input 32-bit
Object code	Array
Data type	Integer32
Category	Optional

Table 133 — Entry description

Attribute	Value
Sub-Index	00 _h
Description	Number of analogue inputs 32-bit
Access	ro
Entry category	Mandatory
PDO mapping	No
Value range	01 _h to FE _h
Default value	No

Sub-Index	01 _h
Description	Analogue input 01 _h
Access	ro
Entry category	Mandatory
PDO mapping	Optional
Value range	Integer32
Default value	No
to	
Sub-Index	02 _h
Description	Analogue input 02 _h
Access	ro
Entry category	Optional
PDO mapping	Optional
Value range	Integer32
Default value	No
to	
Sub-Index	FE _h
Description	Analogue input FE _h
Access	ro
Entry category	Optional
PDO mapping	Optional
Value range	Integer32
Default value	No

8.4.4 Object 6403_h: Read analogue input float

This object shall read the float value of the input channel 'n'. The float value shall be calculated by the following formula:

$$\text{Float value} = \text{integer value} \times \text{input scale} + \text{offset value}$$

Table 134 specifies the object description, and Table 135 specifies the entry description.

Table 134 — Object description

Attribute	Value
INDEX	6403 _h
Name	Read analogue input float
Object code	Array
Data type	Real32
Category	Optional

Table 135 — Entry description

Attribute	Value
Sub-Index	00 _h
Description	Number of analogue inputs float
Access	ro
Entry category	Mandatory
PDO mapping	No
Value range	01 _h to FE _h
Default value	No
Sub-Index	01 _h
Description	Analogue input 01 _h
Access	ro
Entry category	Mandatory
PDO mapping	Optional
Value range	Real32
Default value	No
Sub-Index	02 _h
Description	Analogue input 02 _h
Access	ro
Entry category	Optional
PDO mapping	Optional
Value range	Real32
Default value	No
to	
Sub-Index	FE _h
Description	Analogue input FE _h
Access	ro
Entry category	Optional
PDO mapping	Optional
Value range	Real32
Default value	No

8.4.5 Object 6404_h: Read manufacturer-specific analogue input

This object shall read the manufacturer-specific value of the input channel 'n'.

Table 136 specifies the object description, and Table 137 specifies the entry description.

Table 136 — Object description

Attribute	Value
INDEX	6404 _h
Name	Read manufacturer specific analogue input
Object code	Array
Data type	Manufacturer-specific
Category	Optional

Table 137 — Entry description

Attribute	Value
Sub-Index	00 _h
Description	Number of analogue inputs
Access	ro
Entry category	Mandatory
PDO mapping	No
Value range	01 _h to FE _h
Default value	No
to	
Sub-Index	01 _h
Description	Analogue input 01 _h
Access	ro
Entry category	Mandatory
PDO mapping	Optional
Value range	Manufacturer-specific
Default value	No
to	
Sub-Index	02 _h
Description	Analogue input 02 _h
Access	ro
Entry category	Optional
PDO mapping	Optional
Value range	Manufacturer-specific
Default value	No
to	
Sub-Index	FE _h
Description	Analogue input FE _h
Access	ro
Entry category	Optional
PDO mapping	Optional
Value range	Manufacturer-specific
Default value	No

8.5 Analogue output module

8.5.1 Object 6410_h: Write analogue output 8-bit

This object shall write an integer8 value to the output channel 'n'. The value shall be always left adjusted.

Table 138 specifies the object description, and Table 139 specifies the entry description.

Table 138 — Object description

Attribute	Value
INDEX	6410 _h
Name	Write analogue output 8-bit
Object code	Array
Data type	Integer8
Category	Optional

Table 139 — Entry description

Attribute	Value
Sub-Index	00 _h
Description	Number of analogue outputs 8-bit
Access	ro
Entry category	Mandatory
PDO mapping	No
Value range	01 _h to FE _h
Default value	No
Sub-Index	01 _h
Description	Analogue output 01 _h
Access	rw
Entry category	Mandatory
PDO mapping	Optional
Value range	Integer8
Default value	00 _h
Sub-Index	02 _h
Description	Analogue output 02 _h
Access	rw
Entry category	Optional
PDO mapping	Optional
Value range	Integer8
Default value	00 _h
to	

Sub-Index	FE _n
Description	Analogue output FE _n
Access	rw
Entry category	Optional
PDO mapping	Optional
Value range	Integer8
Default value	00 _h

8.5.2 Object 6411_h: Write analogue output 16-bit

This object shall write an integer16 value to the output channel 'n'. The value shall be always left adjusted.

Table 140 specifies the object description, and Table 141 specifies the entry description.

Table 140 — Object description

Attribute	Value
INDEX	6411 _h
Name	Write analogue output 16-bit
Object code	Array
Data type	Integer16
Category	Conditional: Device with analogue output

Table 141 — Entry description

Attribute	Value
Sub-Index	00 _h
Description	Number of analogue outputs 16-bit
Access	ro
Entry category	Mandatory
PDO mapping	No
Value range	01 _h to FE _h
Default value	No
Sub-Index	01 _h
Description	Analogue output 01 _h
Access	rw
Entry category	Mandatory
PDO mapping	Default
Value range	Integer16
Default value	0000 _h

Sub-Index	02 _h
Description	Analogue output 02 _h
Access	rw
Entry category	Optional
PDO mapping	Default
Value range	Integer
Default value	0000 _h
to	
Sub-Index	0C _h
Description	Analogue output 0C _h
Access	rw
Entry category	Optional
PDO mapping	Default
Value range	Integer16
Default value	0000 _h
to	
Sub-Index	0D _h
Description	Analogue output 0D _h
Access	rw
Entry category	Optional
PDO mapping	Optional
Value range	Integer16
Default value	0000 _h
to	
Sub-Index	FE _h
Description	Analogue output FE _h
Access	rw
Entry category	Optional
PDO mapping	Optional
Value range	Integer16
Default value	0000 _h

8.5.3 Object 6412_h: Write analogue output 32-bit

This object shall write an integer32 value to the output channel 'n'. The value shall be always left adjusted.

Table 142 specifies the object description, and Table 143 specifies the entry description.

Table 142 — Object description

Attribute	Value
INDEX	6412 _h
Name	Write analogue output 32-bit
Object code	Array
Data type	Integer32
Category	Optional

Table 143 — Entry description

Attribute	Value
Sub-Index	00 _n
Description	Number of analogue outputs 32-bit
Access	ro
Entry category	Mandatory
PDO mapping	No
Value range	01 _n to FE _n
Default value	No
Sub-Index	01 _n
Description	Analogue output 01 _n
Access	rw
Entry category	Mandatory
PDO mapping	Optional
Value range	Integer32
Default value	0000 0000 _n
Sub-Index	02 _n
Description	Analogue output 02 _n
Access	rw
Entry category	Optional
PDO mapping	Optional
Value range	Integer32
Default value	0000 0000 _n
to	
Sub-Index	FE _n
Description	Analogue output FE _n
Access	rw
Entry category	Optional
PDO mapping	Optional
Value range	Integer32
Default value	0000 0000 _n

8.5.4 Object 6413_n: Write analogue output float

This object shall write the float value to the output channel 'n'. The Integer value shall be calculated by the following formula:

$$\text{Integer value} = \frac{\text{Float value} - \text{Output offset}}{\text{Output scale}}$$

Table 144 specifies the object description, and Table 145 specifies the entry description.

Table 144 — Object description

Attribute	Value
INDEX	6413 _h
Name	Write analogue output float
Object code	Array
Data type	Real32
Category	Optional

Table 145 — Entry description

Attribute	Value
Sub-Index	00 _h
Description	Number of analogue outputs float
Access	ro
Entry category	Mandatory
PDO mapping	No
Value range	01 _h to FE _h
Default value	No
Sub-Index	01 _h
Description	Analogue output 01 _h
Access	rw
Entry category	Mandatory
PDO mapping	Optional
Value range	Real32
Default value	0,0
Sub-Index	02 _h
Description	Analogue output 02 _h
Access	rw
Entry category	Optional
PDO mapping	Optional
Value range	Real32
Default value	0,0
to	
Sub-Index	FE _h
Description	Analogue output FE _h
Access	rw
Entry category	Optional
PDO mapping	Optional
Value range	Real32
Default value	0,0

8.5.5 Object 6414_h: Write manufacturer-specific analogue output

Writes the manufacturer-specific value to the output channel 'n'.

Table 146 specifies the object description, and Table 147 specifies the entry description.

Table 146 — Object description

Attribute	Value
INDEX	6414 _h
Name	Write manufacturer specific analogue output
Object code	Record or Array
Data type	Manufacturer-specific
Category	Optional

Table 147 — Entry description

Attribute	Value
Sub-Index	00 _h
Description	Number of analogue outputs
Access	ro
Entry category	Mandatory
PDO mapping	No
Value range	01 _h to FE _h
Default value	No
Sub-Index	01 _h
Description	Analogue output 01 _h
Access	rw
Entry category	Mandatory
PDO mapping	Optional
Value range	Manufacturer-specific
Default value	Manufacturer-specific
Sub-Index	02 _h
Description	Analogue output 02 _h
Access	rw
Entry category	Optional
PDO mapping	Optional
Value range	Manufacturer-specific
Default value	Manufacturer-specific
to	

Sub-Index	FE _n
Description	Analogue output FE _n
Access	rw
Entry category	Optional
PDO mapping	Optional
Value range	Manufacturer-specific
Default value	Manufacturer-specific

8.6 Analogue input set-ups

8.6.1 Object 6420_h

Reserved for compatibility reason.

8.6.2 Object 6421_h: Analogue input interrupt trigger selection

This object determines, which events shall cause an interrupt for a specific channel. Figure 8 specifies the object structure and Table 148 specifies the value definition. All bits set to 1_b shall trigger the corresponding analogue input. If the object is not supported, the device shall behave accordingly to the default value.

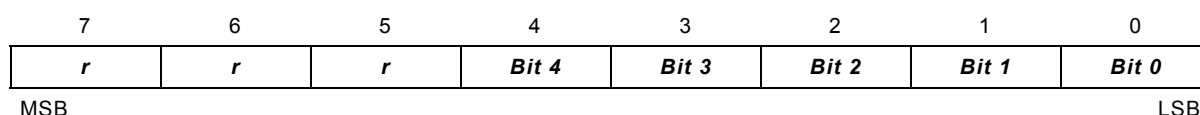

Figure 8 — Object structure

Table 148 — Value definition

Field	Value	Definition
<i>Bit 0</i>	0 _b 1 _b	Upper limit not exceeded Upper limit exceeded
<i>Bit 1</i>	0 _b 1 _b	Input not below lower limit Input below lower limit
<i>Bit 2</i>	0 _b 1 _b	Input not changed by more than delta Input changed by more than delta
<i>Bit 3</i>	0 _b 1 _b	Input not reduced by more than negative delta Input reduced by more than negative delta
<i>Bit 4</i>	0 _b 1 _b	Input not increased by more than positive delta Input increased by more than positive delta
<i>r</i>	0 _b	Reserved for future use

Table 149 specifies the object description, and Table 150 specifies the entry description.

Table 149 — Object description

Attribute	Value
INDEX	6421 _h
Name	Interrupt trigger selection
Object code	Array
Data type	Unsigned8
Category	Optional

Table 150 — Entry description

Attribute	Value
Sub-Index	00 _h
Description	Number of analogue inputs
Access	ro
Entry category	Mandatory
PDO mapping	No
Value range	01 _h to FE _h
Default value	No
Sub-Index	01 _h
Description	Analogue input 01 _h
Access	rw
Entry category	Mandatory
PDO mapping	Optional
Value range	See above
Default value	07 _h
Sub-Index	02 _h
Description	Analogue input 02 _h
Access	rw
Entry category	Optional
PDO mapping	Optional
Value range	See above
Default value	07 _h
Sub-Index	FE _h
Description	Analogue input FE _h
Access	rw
Entry category	Optional
PDO mapping	Optional
Value range	See above
Default value	07 _h

8.6.3 Object 6422_h: Analogue input interrupt source

This object shall determine, which channel has produced an interrupt. Bits set shall relate to the number of any channels that have produced interrupts. The bits shall be reset automatically after read by SDO or transmitted by means of a PDO.

1 = interrupt produced

0 = no interrupt produced

If the object is not supported, the device shall behave accordingly to the default value.

Table 151 specifies the object description, and Table 152 specifies the entry description.

Table 151 — Object description

Attribute	Value
INDEX	6422 _h
Name	Analogue input Interrupt Source
Object code	Array
Data type	Unsigned32
Category	Optional

Table 152 — Entry description

Attribute	Value
Sub-Index	00 _h
Description	Number of interrupt source banks
Access	ro
Entry category	Mandatory
PDO mapping	No
Value range	01 _h to 08 _h
Default value	No
to	
Sub-Index	01 _h
Description	Interrupt source bank 01 _h
Access	ro
Entry category	Mandatory
PDO mapping	Optional
Value range	Unsigned32
Default value	No
to	
Sub-Index	02 _h
Description	Interrupt source bank 02 _h
Access	ro
Entry category	Optional
PDO mapping	Optional
Value range	Unsigned32
Default value	No
to	
Sub-Index	08 _h
Description	Interrupt source bank 08 _h
Access	ro
Entry category	Optional
PDO mapping	Optional
Value range	Unsigned32
Default value	No

8.6.4 Object 6423_h: Analogue input global interrupt enable

This object shall enable and disable globally the interrupt behavior without changing the interrupt mask. By default, no analogue input activates an interrupt.

TRUE = global interrupt enabled

FALSE = global interrupt disabled

Table 153 specifies the object description, and Table 154 specifies the entry description.

Table 153 — Object description

Attribute	Value
INDEX	6423 _h
Name	Analogue input global interrupt enable
Object code	Variable
Data type	Boolean
Category	Conditional: Device with analogue input

Table 154 — Entry description

Attribute	Value
Sub-Index	00 _h
Access	rw
PDO mapping	Optional
Value range	Boolean
Default value	FALSE

8.6.5 Object 6424_h: Analogue input interrupt upper limit integer

If enabled (see 6423_h object), an interrupt is triggered when the analogue input is equal or rises above the given value. The value shall be always left adjusted. As long as the trigger condition is met, every change of the analogue input data generates a new interrupt, if there is no additional trigger condition, e.g. an input interrupt delta (6426_h).

If the object is not supported, the device shall behave accordingly to the default value.

Configuration of the analogue input interrupt upper limit float object (6429_h) shall cause also value change in the 6424_h object and vice versa.

NOTE The value of this object is not scaled and not offset.

Table 155 specifies the object description, and Table 156 specifies the entry description.

Table 155 — Object description

Attribute	Value
INDEX	6424 _h
Name	Analogue input Interrupt upper limit integer
Object code	Array
Data type	Integer32
Category	Optional

Table 156 — Entry description

Attribute	Value
Sub-Index	00 _h
Description	Number of analogue inputs
Access	ro
Entry category	Mandatory
PDO mapping	No
Value range	01 _h to FE _h
Default	No
Sub-Index	01 _h
Description	Analogue input 01 _h
Access	rw
Entry category	Mandatory
PDO mapping	Optional
Value range	Integer32
Default value	0000 0000 _h
Sub-Index	02 _h
Description	Analogue input 02 _h
Access	rw
Entry category	Optional
PDO mapping	Optional
Value range	Integer32
Default value	0000 0000 _h
to	
Sub-Index	FE _h
Description	Analogue input FE _h
Access	rw
Entry category	Optional
PDO mapping	Optional
Value range	Integer32
Default value	0000 0000 _h

8.6.6 Object 6425_h: Analogue input interrupt lower limit integer

If enabled (see 6423_h object), an interrupt is triggered when the analogue input falls below the given value. The value shall be always left adjusted. As long as the trigger condition is met, every change of the analogue input data generates a new interrupt, if there is no additional trigger condition, e.g. an input interrupt delta (6426_h).

If the object is not supported, the device shall behave accordingly to the default value.

Configuration of the analogue input interrupt lower limit float object (642A_h) shall cause also value change in the 6425_h object and vice versa.

NOTE The value of this object is not scaled and not offset.

Table 157 specifies the object description, and Table 158 specifies the entry description.

Table 157 — Object description

Attribute	Value
INDEX	6425 _h
Name	Analogue input interrupt lower limit integer
Object code	Array
Data type	Integer32
Category	Optional

Table 158 — Entry description

Attribute	Value
Sub-Index	00 _h
Description	Number of analogue inputs
Access	ro
Entry category	Mandatory
PDO mapping	No
Value range	01 _h to FE _h
Default value	No
Sub-Index	01 _h
Description	Analogue input 01 _h
Access	rw
Entry category	Optional
PDO mapping	Optional
Value range	Integer32
Default value	0000 0000 _h
Sub-Index	02 _h
Description	Analogue input 02 _h
Access	rw
Entry category	Optional
PDO mapping	Optional
Value range	Integer32
Default value	0000 0000 _h
to	
Sub-Index	FE _h
Description	Analogue input FE _h
Access	rw
Entry category	Optional
PDO mapping	Optional
Value range	Integer32
Default value	0000 0000 _h

8.6.7 Object 6426_h: Analogue input interrupt delta unsigned

This object shall set the delta value (rising or falling above or below the last communicated value) for interrupt-enabled analogue inputs (see 6423_h object).

If the object is not supported, the device shall behave accordingly to the default value.

Configuration of the analogue input interrupt delta float object (642B_h) shall cause also value change in 6426_h object and vice versa.

NOTE The value of this object is not scaled and not offset.

Table 159 specifies the object description, and Table 160 specifies the entry description.

Table 159 — Object description

Attribute	Value
INDEX	6426 _h
Name	Analogue input interrupt delta unsigned
Object code	Array
Data type	Unsigned32
Category	Optional

Table 160 — Entry description

Attribute	Value
Sub-Index	00 _h
Description	Number of analogue inputs
Access	ro
Entry category	Mandatory
PDO mapping	No
Value range	01 _h to FE _h
Default value	No
Sub-Index	01 _h
Description	Analogue input 01 _h
Access	rw
Entry category	Mandatory
PDO mapping	Optional
Value range	Unsigned32
Default value	0000 0000 _h
Sub-Index	02 _h
Description	Analogue input 02 _h
Access	rw
Entry category	Optional
PDO mapping	Optional
Value range	Unsigned32
Default value	0000 0000 _h
to	

Sub-Index	FE _h
Description	Analogue input FE _h
Access	rw
Entry category	Optional
PDO mapping	Optional
Value range	Unsigned32
Default value	0000 0000 _h

8.6.8 Object 6427_h: Analogue input interrupt negative delta unsigned

This object shall set the negative delta value (falling below the last communicated value) for interrupt-enabled analogue inputs (see 6423_h object).

If the object is not supported, the device shall behave accordingly to the default value.

Configuration of the analogue input interrupt negative delta float object (642C_h) shall cause also value change in the 6427_h object and vice versa.

NOTE The value of this object is not scaled and not offset.

Table 161 specifies the object description, and Table 162 specifies the entry description.

Table 161 — Object description

Attribute	Value
INDEX	6427 _h
Name	Analogue input interrupt negative delta unsigned
Object code	Array
Data type	Unsigned32
Category	Optional

Table 162 — Entry description

Attribute	Value
Sub-Index	00 _h
Description	Number of analogue inputs
Access	ro
Entry category	Mandatory
PDO mapping	No
Value range	01 _h to FE _h
Default value	No
Sub-Index	01 _h
Description	Analogue input 01 _h
Access	rw
Entry category	Mandatory
PDO mapping	Optional
Value range	Unsigned32
Default value	0000 0000 _h

Sub-Index	02 _h
Description	Analogue input 02 _h
Access	rw
Entry category	Optional
PDO mapping	Optional
Value range	Unsigned32
Default value	0000 0000 _h
to	
Sub-Index	FE _h
Description	Analogue input FE _h
Access	rw
Entry category	Optional
PDO mapping	Optional
Value range	Unsigned32
Default value	0000 0000 _h

8.6.9 Object 6428_h: Analogue input interrupt positive delta unsigned

This object shall set the positive delta value (rising above the last communicated value) for interrupt-enabled analogue inputs (see 6423_h object).

If the object is not supported, the device shall behave accordingly to the default value.

Configuration of the analogue input interrupt positive delta float object (642D_h) shall cause also value change in the 6428_h object and vice versa.

NOTE The value of this object is not scaled and not offset.

Table 163 specifies the object description, and Table 164 specifies the entry description.

Table 163 — Object description

Attribute	Value
INDEX	6428 _h
Name	Analogue input interrupt positive delta unsigned
Object code	Array
Data type	Unsigned32
Category	Optional

Table 164 — Entry description

Attribute	Value
Sub-Index	00 _h
Description	Number of analogue inputs
Access	ro
Entry category	Mandatory
PDO mapping	No
Value range	01 _h to FE _h
Default value	No

Sub-Index	01 _h
Description	Analogue input 01 _h
Access	rw
Entry category	Mandatory
PDO mapping	Optional
Value range	Unsigned32
Default value	0000 0000 _h
Sub-Index	02 _h
Description	Analogue input 02 _h
Access	rw
Entry category	Optional
PDO mapping	Optional
Value range	Unsigned32
Default value	0000 0000 _h
to	
Sub-Index	FE _h
Description	Analogue input FE _h
Access	rw
Entry category	Optional
PDO mapping	Optional
Value range	Unsigned32
Default value	0000 0000 _h

8.6.10 Object 6429_h: Analogue input interrupt upper limit float

This object shall set the converted upper limits for interrupt-enabled analogue inputs (see 6423_h object). As long as the trigger condition is met, every change of the analogue input data generates a new interrupt, if there is no additional trigger condition, e.g. an input interrupt delta (642B_h).

If the object is not supported, the device shall behave accordingly to the default value.

Configuration of the analogue input interrupt upper limit integer object (6424_h) shall cause also value change in the 6429_h object and vice versa.

NOTE The value of this object is not scaled and not offset.

Table 165 specifies the object description, and Table 166 specifies the entry description.

Table 165 — Object description

Attribute	Value
INDEX	6429 _h
Name	Analogue input interrupt upper limit float
Object code	Array
Data type	Real32
Category	Optional

Table 166 — Entry description

Attribute	Value
Sub-Index	00 _h
Description	Number of analogue inputs
Access	ro
Entry category	Mandatory
PDO mapping	No
Value range	01 _h to FE _h
Default value	No
Sub-Index	01 _h
Description	Analogue input 01 _h
Access	rw
Entry category	Mandatory
PDO mapping	Optional
Value range	Real32
Default value	0,0
Sub-Index	02 _h
Description	Analogue input 02 _h
Access	rw
Entry category	Optional
PDO mapping	Optional
Value range	Real32
Default value	0,0
to	
Sub-Index	FE _h
Description	Analogue input FE _h
Access	rw
Entry category	Optional
PDO mapping	Optional
Value range	Real32
Default value	0,0

8.6.11 Object 642A_h: Analogue input interrupt lower limit float

This object shall set the lower limits for interrupt-enabled analogue inputs (see 6423_h object). As long as the trigger condition is met, every change of the analogue input data generates a new interrupt, if there is no additional trigger condition, e.g. an input interrupt delta (642B_h).

If the object is not supported, the device shall behave accordingly to the default value.

Configuration of the analogue input interrupt lower limit integer object (6425_h) shall cause also value change in the 642A_h object and vice versa.

NOTE The value of this object is not scaled and not offset.

Table 167 specifies the object description, and Table 168 specifies the entry description.

Table 167 — Object description

Attribute	Value
INDEX	642A _h
Name	Analogue input interrupt lower limit float
Object code	Array
Data type	Real32
Category	Optional

Table 168 — Entry description

Attribute	Value
Sub-Index	00 _h
Description	Number analogue inputs
Access	ro
Entry category	Mandatory
PDO mapping	No
Value range	01 _h to FE _h
Default value	No
Sub-Index	01 _h
Description	Analogue input 01 _h
Access	rw
Entry category	Mandatory
PDO mapping	Optional
Value range	Real32
Default value	0,0
Sub-Index	02 _h
Description	Analogue input 02 _h
Access	rw
Entry category	Optional
PDO mapping	Optional
Value range	Real32
Default value	0,0
to	
Sub-Index	FE _h
Description	Analogue input FE _h
Access	rw
Entry category	Optional
PDO mapping	Optional
Value range	Real32
Default value	0,0

8.6.12 Object 642B_h: Analogue input interrupt delta float

This object shall set the delta value (rising or falling above or below the last sample) in float format for interrupt-enabled analogue inputs (see 6423_h object).

If the object is not supported, the device shall behave accordingly to the default value.

Configuration of the analogue input interrupt delta unsigned object (6426_h) shall cause also value change in the 642B_h object and vice versa.

NOTE The value of this object is not scaled and not offset.

Table 169 specifies the object description, and Table 170 specifies the entry description.

Table 169 — Object description

Attribute	Value
INDEX	642B _h
Name	Analogue input interrupt delta float
Object code	Array
Data type	Real32
Category	Optional

Table 170 — Entry description

Attribute	Value
Sub-Index	00 _h
Description	Number of analogue inputs
Access	ro
Entry category	Mandatory
PDO mapping	No
Value range	01 _h to FE _h
Default value	No
Sub-Index	01 _h
Description	Analogue input 01 _h
Access	rw
Entry category	Mandatory
PDO mapping	Optional
Value range	Real32
Default value	0,0
Sub-Index	02 _h
Description	Analogue input 02 _h
Access	rw
Entry category	Optional
PDO mapping	Optional
Value range	Real32
Default value	0,0
to	

Sub-Index	FE _h
Description	Analogue input FE _h
Access	rw
Entry category	Optional
PDO mapping	Optional
Value range	Real32
Default value	0,0

8.6.13 Object 642C_h: Analogue input interrupt negative delta float

This object shall set the negative delta value (falling below the last sample) in float format for interrupt-enabled analogue inputs (see 6423_h object).

If the object is not supported, the device shall behave accordingly to the default value.

Configuration of the analogue input interrupt negative delta unsigned object (6427_h) shall cause also value change in the 642C_h object and vice versa.

NOTE The value of this object is not scaled and not offset.

Table 171 specifies the object description, and Table 172 specifies the entry description.

Table 171 — Object description

Attribute	Value
INDEX	642C _h
Name	Analogue input interrupt negative delta float
Object code	Array
Data type	Real32
Category	Optional

Table 172 — Entry description

Attribute	Value
Sub-Index	00 _h
Description	Number of analogue inputs
Access	ro
Entry category	Mandatory
PDO mapping	No
Value range	01 _h to FE _h
Default value	No
Sub-Index	01 _h
Description	Analogue input 01 _h
Access	rw
Entry category	Mandatory
PDO mapping	Optional
Value range	Real32
Default value	0,0

Sub-Index	02 _h
Description	Analogue input 02 _h
Access	rw
Entry category	Optional
PDO mapping	Optional
Value range	Real32
Default value	0,0
to	
Sub-Index	FE _h
Description	Analogue input FE _h
Access	rw
Entry category	Optional
PDO mapping	Optional
Value range	Real32
Default value	0,0

8.6.14 Object 642D_h: Analogue input interrupt positive delta float

This object shall set the positive delta value (rising above the last sample) in float format for interrupt-enabled analogue inputs (see 6423_h object).

If the object is not supported, the device shall behave accordingly to the default value.

Configuration of the analogue input interrupt positive delta unsigned object (6428_h) shall cause also value change in the 642D_h object and vice versa.

NOTE The value of this object is not scaled and not offset.

Table 173 specifies the object description, and Table 174 specifies the entry description.

Table 173 — OBJECT DESCRIPTION

Attribute	Value
INDEX	642D _h
Name	Analogue input interrupt positive delta float
Object code	Array
Data type	Real32
Category	Optional

Table 174 — ENTRY DESCRIPTION

Attribute	Value
Sub-Index	00 _h
Description	Number of analogue inputs
Access	ro
Entry category	Mandatory
PDO mapping	No
Value range	01 _h to FE _h
Default value	No

Sub-Index	01 _h
Description	Analogue input 01 _h
Access	rw
Entry category	Mandatory
PDO mapping	Optional
Value range	Real32
Default value	0,0
to	
Sub-Index	02 _h
Description	Analogue input 02 _h
Access	rw
Entry category	Optional
PDO mapping	Optional
Value range	Real32
Default value	0,0
to	
Sub-Index	FE _h
Description	Analogue input FE _h
Access	rw
Entry category	Optional
PDO mapping	Optional
Value range	Real32
Default value	0,0

8.6.15 Object 642E_h: Analogue input offset float

This object shall set the offsets in float format for input data (6403_h object) for channel 'n'.

If the object is not supported, the device shall behave accordingly to 6431_h object, or if that object is also not supported, the device shall behave accordingly to the default value.

Configuration of the analogue input offset integer object (6431_h) shall cause also value change in the 642E_h object and vice versa.

Table 175 specifies the object description, and Table 176 specifies the entry description.

Table 175 — OBJECT DESCRIPTION

Attribute	Value
INDEX	642E _h
Name	Analogue input offset float
Object code	Array
Data type	Real32
Category	Optional

Table 176 — ENTRY DESCRIPTION

Attribute	Value
Sub-Index	00 _h
Description	Number of analogue inputs
Access	ro
Entry category	Mandatory
PDO mapping	No
Value range	01 _h to FE _h
Default value	No
Sub-Index	01 _h
Description	Analogue input 01 _h
Access	rw
Entry category	Mandatory
PDO mapping	Optional
Value range	Real32
Default value	0,0
Sub-Index	02 _h
Description	Analogue input 02 _h
Access	rw
Entry category	Optional
PDO mapping	Optional
Value range	Real32
Default value	0,0
to	
Sub-Index	FE _h
Description	Analogue input FE _h
Access	rw
Entry category	Optional
PDO mapping	Optional
Value range	Real32
Default value	0,0

8.6.16 Object 642F_h: Analogue input pre-scaling float

This object shall set the pre-scaling in float format for input data (6403_h object).

If the object is not supported, the device shall behave accordingly to 6432_h object, or if that object is also not supported, the device shall behave accordingly to the default value.

Configuration of the analogue input pre-scaling integer object (6432_h) shall cause also value change in the 642F_h object and vice versa.

Table 177 specifies the object description, and Table 178 specifies the entry description.

Table 177 — OBJECT DESCRIPTION

Attribute	Value
INDEX	642F _h
Name	Analogue input pre-scaling float
Object code	Array
Data type	Real32
Category	Optional

Table 178 — Entry description

Attribute	Value
Sub-Index	00 _h
Description	Number of analogue inputs
Access	ro
Entry category	Mandatory
PDO mapping	No
Value range	01 _h to FE _h
Default value	No
Sub-Index	01 _h
Description	Analogue input 01 _h
Access	rw
Entry category	Mandatory
PDO mapping	Optional
Value range	Real32
Default value	1,0
Sub-Index	02 _h
Description	Analogue input 02 _h
Access	rw
Entry category	Optional
PDO mapping	Optional
Value range	Real32
Default value	1,0
to	
Sub-Index	FE _h
Description	Analogue input FE _h
Access	rw
Entry category	Optional
PDO mapping	Optional
Value range	Real32
Default value	1,0

8.6.17 Object 6430_h: Analogue input SI unit

This object shall assign SI units and prefixes for analogue inputs. The value structure is defined in Figure 9.

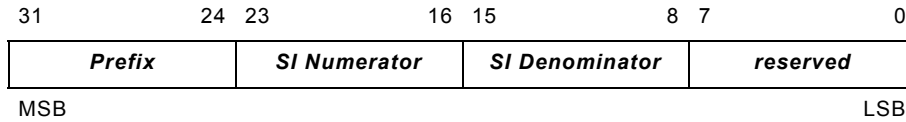

Figure 9 — Value structure

The values for prefix, SI numerator, and SI denominator are specified in /CiA303-2/.

Table 179 specifies the object description, and Table 180 specifies the entry description.

Table 179 — Object description

Attribute	Value
INDEX	6430 _h
Name	Analogue input SI unit
Object code	Array
Data type	Unsigned32
Category	Optional

Table 180 — Entry description

Attribute	Value
Sub-Index	00 _h
Description	Number of analogue inputs
Access	ro
Entry category	Mandatory
PDO mapping	No
Value range	01 _h to FE _h
Default value	No
Sub-Index	01 _h
Description	Analogue input 01 _h
Access	rw
Entry category	Mandatory
PDO mapping	Optional
Value range	Unsigned32
Default value	No

Sub-Index	02 _h
Description	Analogue input 02 _h
Access	rw
Entry category	Optional
PDO mapping	Optional
Value range	Unsigned32
Default value	No
to	
Sub-Index	FE _h
Description	Analogue input FE _h
Access	rw
Entry category	Optional
PDO mapping	Optional
Value range	Unsigned32
Default value	No

8.6.18 Object 6431_h: Analogue input offset integer

This object shall set the offset in integer format for input data (6403_h object).

If the object is not supported, the device shall behave accordingly to 642E_h object, or if that object is also not supported, the device shall behave accordingly to the default value.

Configuration of the analogue input offset float object (642E_h) shall cause also value change in the 6431_h object and vice versa.

Table 181 specifies the object description, and Table 182 specifies the entry description.

Table 181 — Object description

Attribute	Value
INDEX	6431 _h
Name	Analogue input offset integer
Object code	Array
Data type	Integer32
Category	Optional

Table 182 — Entry description

Attribute	Value
Sub-Index	00 _h
Description	Number of analogue inputs
Access	ro
Entry category	Mandatory
PDO mapping	No
Value range	01 _h to FE _h
Default value	No

Sub-Index	01 _h
Description	Analogue input 01 _h
Access	rw
Entry category	Mandatory
PDO mapping	Optional
Value range	Integer32
Default value	0000 0000 _h
to	
Sub-Index	02 _h
Description	Analogue input 02 _h
Access	rw
Entry category	Optional
PDO mapping	Optional
Value range	Integer32
Default value	0000 0000 _h
to	
Sub-Index	FE _h
Description	Analogue input FE _h
Access	rw
Entry category	Optional
PDO mapping	Optional
Value range	Integer32
Default value	0000 0000 _h

8.6.19 Object 6432_h: Analogue input pre-scaling integer

This object shall set the pre-scaling in integer format or input data (6403_h object).

If the object is not supported, the device shall behave accordingly to 642F_h object, or if that object is also not supported, the device shall behave accordingly to the default value.

Configuration of the analogue input pre-scaling float object (642F_h) shall cause also value change in the 6432_h object and vice versa.

Table 183 specifies the object description, and Table 184 specifies the entry description.

Table 183 — Object description

Attribute	Value
INDEX	6432 _h
Name	Analogue input pre-scaling integer
Object code	Array
Data type	Integer32
Category	Optional

Table 184 — Entry description

Attribute	Value
Sub-Index	00 _h
Description	Number of analogue inputs
Access	ro
Entry category	Mandatory
PDO mapping	No
Value range	01 _h to FE _h
Default value	No
Sub-Index	01 _h
Description	Analogue input 01 _h
Access	rw
Entry category	Mandatory
PDO mapping	Optional
Value range	Integer32
Default value	0000 0001 _h
Sub-Index	02 _h
Description	Analogue input 02 _h
Access	rw
Entry category	Optional
PDO mapping	Optional
Value range	Integer32
Default value	0000 0001 _h
to	
Sub-Index	FE _h
Description	Analogue input FE _h
Access	rw
Entry category	Optional
PDO mapping	Optional
Value range	Integer32
Default value	0000 0001 _h

8.7 Analogue output set-ups

8.7.1 Object 6440_h

Reserved for compatibility reason.

8.7.2 Object 6441_h: Analogue output offset float

This object shall set the offset in float format for output data (6413_h object).

If the object is not supported, the device shall behave accordingly to 6446_h object, or if that object is also not supported, the device shall behave accordingly to the default value.

Configuration of the analogue output offset integer object (6446_h) shall cause also value change in the 6441_h object and vice versa.

Table 185 specifies the object description, and Table 186 specifies the entry description.

Table 185 — Object description

Attribute	Value
INDEX	6441 _h
Name	Analogue output offset float
Object code	Array
Data type	Real32
Category	Optional

Table 186 — Entry description

Attribute	Value
Sub-Index	00 _h
Description	Number of analogue outputs
Access	ro
Entry category	Mandatory
PDO mapping	No
Value range	01 _h to FE _h
Default value	No
Sub-Index	01 _h
Description	Analogue output 01 _h
Access	rw
Entry category	Mandatory
PDO mapping	Optional
Value range	Real32
Default value	0,0
Sub-Index	02 _h
Description	Analogue output 02 _h
Access	rw
Entry category	Optional
PDO mapping	Optional
Value range	Real32
Default value	0,0
to	

Sub-Index	FE _n
Description	Analogue output FE _n
Access	rw
Entry category	Optional
PDO mapping	Optional
Value range	Real32
Default value	0,0

8.7.3 Object 6442_h: Analogue output scaling float

This object shall set the scaling in float format for output data (6413_h object).

If the object is not supported, the device shall behave accordingly to 6447_h object, or if that object is also not supported, the device shall behave accordingly to the default value.

Configuration of the analogue output scaling integer object (6447_h) shall cause also value change in the 6442_h object and vice versa.

Table 187 specifies the object description, and Table 188 specifies the entry description.

Table 187 — Object description

Attribute	Value
INDEX	6442 _h
Name	Analogue output scaling float
Object code	Array
Data type	Real32
Category	Optional

Table 188 — Entry description

Attribute	Value
Sub-Index	00 _h
Description	Number of analogue outputs
Access	ro
Entry category	Mandatory
PDO mapping	No
Value range	01 _h to FE _h
Default value	No
Sub-Index	01 _h
Description	Analogue output 01 _h
Access	rw
Entry category	Mandatory
PDO mapping	Optional
Value range	Real32
Default value	1,0

Sub-Index	02 _h
Description	Analogue output 02 _h
Access	rw
Entry category	Optional
PDO mapping	Optional
Value range	Real32
Default	1,0
to	
Sub-Index	FE _h
Description	Analogue output FE _h
Access	rw
Entry category	Optional
PDO mapping	Optional
Value range	Real32
Default	1,0

8.7.4 Object 6443_h: Analogue output error mode

This object defines, whether an output is set to a pre-defined error value (see 6444_h object) in case of an internal device failure or a 'Stop remote node' indication.

0_h = actual value rest 1_h = reverts to error value integer (6444_h)
 others = reserved

If the object is not supported, the device shall behave accordingly to the default value.

Table 189 specifies the object description, and Table 190 specifies the entry description.

Table 189 — Object description

Attribute	Value
INDEX	6443 _h
Name	Analogue output error mode
Object code	Array
Data type	Unsigned8
Category	Optional

Table 190 — Entry description

Attribute	Value
Sub-Index	00 _h
Description	Number of analogue outputs
Access	ro
Entry category	Mandatory
PDO mapping	No
Value range	01 _h to FE _h
Default value	No

Sub-Index	01 _h
Description	Error mode analogue output 01 _h
Access	rw
Entry category	Mandatory
PDO mapping	Optional
Value range	Unsigned8
Default value	01 _h
to	
Sub-Index	02 _h
Description	Error mode analogue output 02 _h
Access	rw
Entry category	Optional
PDO mapping	Optional
Value range	Unsigned8
Default value	01 _h
to	
Sub-Index	FE _h
Description	Error mode analogue output FE _h
Access	rw
Entry category	Optional
PDO mapping	Optional
Value range	Unsigned8
Default value	01 _h

8.7.5 Object 6444_h: Analogue output error value integer

On condition that the corresponding Error mode is active, device failures (see chapter 5.2) shall set the outputs to the value configured by this object.

If the object is not supported, the device shall behave accordingly to 6445_h object, or if that object is also not supported, the device shall behave accordingly to the default value.

Configuration of the analogue output error value float object (6445_h) shall cause also value change in the 6444_h object and vice versa.

NOTE The value of this object is not scaled and not offset.

Table 191 specifies the object description, and Table 192 specifies the entry description.

Table 191 — Object description

Attribute	Value
INDEX	6444 _h
Name	Analogue output error value integer
Object code	Array
Data type	Integer32
Category	Optional

Table 192 — Entry description

Attribute	Value
Sub-Index	00 _h
Description	Number of analogue outputs
Access	ro
Entry category	Mandatory
PDO mapping	No
Value range	01 _h to FE _h
Default value	No
Sub-Index	01 _h
Description	Analogue output 01 _h
Access	rw
Entry category	Mandatory
PDO mapping	Optional
Value range	Integer32
Default value	0000 0000 _h
Sub-Index	02 _h
Description	Analogue output 02 _h
Access	rw
Entry category	Optional
PDO mapping	Optional
Value range	Integer32
Default value	0000 0000 _h
to	
Sub-Index	FE _h
Description	Analogue output FE _h
Access	rw
Entry category	Optional
PDO mapping	Optional
Value range	Integer32
Default value	0000 0000 _h

8.7.8 Object 6445_h: Analogue output error value float

On condition that the corresponding error mode is active, device failures (see chapter 5.2) shall set the outputs to the value configured by this object.

If the object is not supported, the device shall behave accordingly to 6444_h object, or if that object is also not supported, the device shall behave accordingly to the default value.

Configuration of the analogue output error value integer object (6444_h) shall cause also value change in the 6445_h object and vice versa.

NOTE The value of this object is not scaled and not offset.

Table 193 specifies the object description, and Table 194 specifies the entry description.

Table 193 — Object description

Attribute	Value
INDEX	6445 _h
Name	Analogue output error value float
Object code	Array
Data type	Real32
Category	Optional

Table 194 — Entry description

Attribute	Value
Sub-Index	00 _h
Description	Number of analogue outputs
Access	ro
Entry category	Mandatory
PDO mapping	No
Value range	01 _h to FE _h
Default value	No
Sub-Index	01 _h
Description	Analogue output 01 _h
Access	rw
Entry category	Mandatory
PDO mapping	Optional
Value range	Real32
Default value	0,0
Sub-Index	02 _h
Description	Analogue output 02 _h
Access	rw
Entry category	Optional
PDO mapping	Optional
Value range	Real32
Default value	0,0
to	
Sub-Index	FE _h
Description	Analogue output FE _h
Access	rw
Entry category	Optional
PDO mapping	Optional
Value range	Real32
Default value	0,0

8.7.9 Object 6446_h: Analogue output offset integer

This object shall set the offset in integer format for output data (6413_h object).

If the object is not supported, the device shall behave accordingly to 6441_h object, or if that object is also not supported, the device shall behave accordingly to the default value.

Configuration of the analogue output offset float object (6441_h) shall cause also value change in the 6446_h object and vice versa.

Table 195 specifies the object description, and Table 196 specifies the entry description.

Table 195 — Object description

Attribute	Value
INDEX	6446 _h
Name	Analogue output offset integer
Object code	Array
Data type	Integer32
Category	Optional

Table 196 — Entry description

Attribute	Value
Sub-Index	00 _h
Description	Number of analogue outputs
Access	ro
Entry category	Mandatory
PDO mapping	No
Value range	01 _h to FE _h
Default value	No
Sub-Index	01 _h
Description	Analogue output 01 _h
Access	rw
Entry category	Mandatory
PDO mapping	Optional
Value range	Integer32
Default value	0000 0000 _h
Sub-Index	02 _h
Description	Analogue output 02 _h
Access	rw
Entry category	Optional
PDO mapping	Optional
Value range	Integer32
Default value	0000 0000 _h
to	

Sub-Index	FE _n
Description	Analogue output FE _n
Access	rw
Entry category	Optional
PDO mapping	Optional
Value range	Integer32
Default value	0000 0000 _n

8.7.10 Object 6447_n: Analogue output scaling integer

This object shall set the scaling in integer format for output data (6413_n object).

If the object is not supported, the device shall behave accordingly to 6442_n object, or if that object is also not supported, the device shall behave accordingly to the default value.

Configuration of the analogue output scaling float object (6442_n) shall cause also value change in the 6447_n object and vice versa.

Table 197 specifies the object description, and Table 198 specifies the entry description.

Table 197 — Object description

Attribute	Value
INDEX	6447 _n
Name	Analogue output scaling integer
Object code	Array
Data type	Integer32
Category	Optional

Table 198 — Entry description

Attribute	Value
Sub-Index	00 _n
Description	Number of analogue outputs
Access	ro
Entry category	Mandatory
PDO mapping	No
Value range	01 _n to FE _n
Default value	No
Sub-Index	01 _n
Description	Analogue output 01 _n
Access	rw
Entry category	Mandatory
PDO mapping	Optional
Value range	Integer32
Default value	0000 0001 _n

Sub-Index	02 _h
Description	Analogue output 02 _h
Access	rw
Entry category	Optional
PDO mapping	Optional
Value range	Integer32
Default	0000 0001 _h
to	
Sub-Index	FE _h
Description	Analogue output FE _h
Access	rw
Entry category	Optional
PDO mapping	Optional
Value range	Integer32
Default	0000 0001 _h

8.7.11 Object 6450_h: Analogue output SI unit

This object shall assign SI units and prefixes for analogue outputs. The value structure is defined in Figure 10.

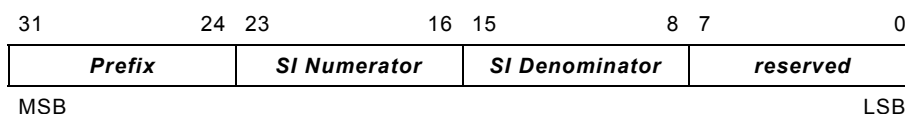

Figure 10 — Value structure

The values for prefix, SI numerator, and SI denominator are specified in /CiA303-2/.

Table 199 specifies the object description, and Table 200 specifies the entry description.

Table 199 — Object description

Attribute	Value
INDEX	6450 _h
Name	Analogue output SI unit
Object code	Array
Data type	Unsigned32
Category	Optional

Table 200 — Entry description

Attribute	Value
Sub-Index	00 _h
Description	Number of analogue outputs
Access	ro
Entry category	Mandatory
PDO mapping	No
Value range	01 _h to FE _h
Default value	No

Sub-Index	01 _h
Description	Analogue output 01 _h
Access	rw
Entry category	Mandatory
PDO mapping	Optional
Value range	Unsigned32
Default value	No
Sub-Index	02 _h
Description	Analogue output 02 _h
Access	rw
Entry category	Optional
PDO mapping	Optional
Value range	Unsigned32
Default value	No
to	
Sub-Index	FE _h
Description	Analogue output FE _h
Access	rw
Entry category	Optional
PDO mapping	Optional
Value range	Unsigned32
Default value	No

8.8 General device profile objects

8.8.1 Object 67FF_h: Device type

This object shall describe the first logical device in a multiple device module according to /CiA301/.

Annex A : Joystick

A.1 Scope

This appendix defines the use of DS-401 for joysticks adopted as a special input module. This input module supports digital inputs and analogue inputs. The digital inputs are the buttons of the joystick and the analogue inputs are the proportional input values. Optional there are digital outputs for indicating LEDs or general purposes.

A.2 Pre-defined communication objects for joysticks

A.2.1 Object 1000_h: Device type

The specific functionality is defined as a joystick with digital and analogue inputs. Table 201 specifies the values.

Table 201 — Value definitions

Additional information		Device profile number	Description
Specific functionality	I/O functionality		
01 _h	05 _h	0191 _h	I/O functionality without digital outputs
01 _h	07 _h	0191 _h	I/O functionality with digital outputs
02 _h	07 _h	0191 _h	Special PDO mapping for 3-D joystick is used
03 _h	07 _h	0191 _h	Special PDO mapping for 2-D joystick is used

A.3 Joystick buttons

The buttons use the functionality for digital inputs with 8-bit access. The 6000_h object shall be supported and the related configuration objects may be implemented.

A.4 Joystick proportional inputs

The proportional inputs representing the joystick position use the functionality for analogue inputs with signed 16-bit access. An analogue value of zero represents the zero position of the joystick. The object 6401_h shall be supported and all related configuration objects may be implemented.

The default value for the object 6430_h (analogue input SI unit) is defined in Figure 11.

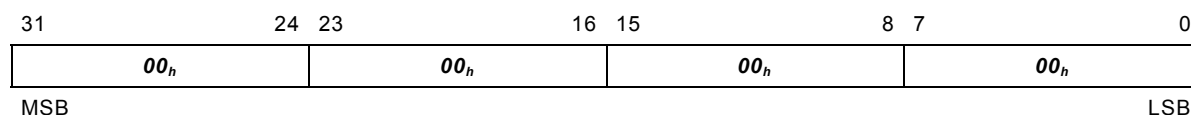

Figure 11 — Default value for object 6430_h

A.5 Joystick PDO mappings

A.5.1 Introduction

The joystick device supports the generic CiA 401 mapping as defined in clause A.5.2 and A.5.3 or the specific joystick mappings as defined in clause A.5.4 and A.5.5.

A.5.2 1st TPDO mapping (buttons)

The first TPDO transmits the values of maximum 8 x 8 buttons. The first 8 buttons (Index 6000_h sub-index 01_h) are defined in Figure 12. The unused bits may be used manufacturer-specific.

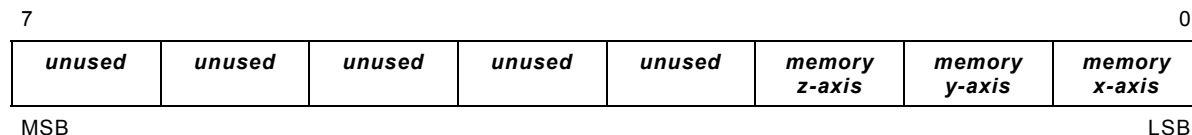

Figure 12 — Structure of object 6000 01_h

The memory buttons for x-, y-, and z-axes shall freeze the proportional values of the related axes:

- 1 = memory function on (freeze proportional values)
- 0 = memory function off (release proportional values)

NOTE It is optional to include the freezing function into the joystick itself. In this case, the proportional values are not modified any more if the memory function is switched on.

Otherwise freezing is done by the application and the buttons are interpreted as freezing request. In this case, the memory buttons have no effect on the proportional input values.

If the joystick does not support memory function, the bits 0 to 2 shall be 0 and the bits 2 to 7 of the first digital input byte (Object 6000 01_h) are used manufacturer-specific.

A.5.3 2nd TPDO mapping (proportional inputs)

The second TPDO transmits the 16-bit values of maximum 4 proportional inputs. The first 3 analogue values (Object 6401 01_h to 03_h) are used for the three dimensions (x, y, z), the other analogue value is manufacturer-specific.

Figure 13 shows the structure of this TPDO.

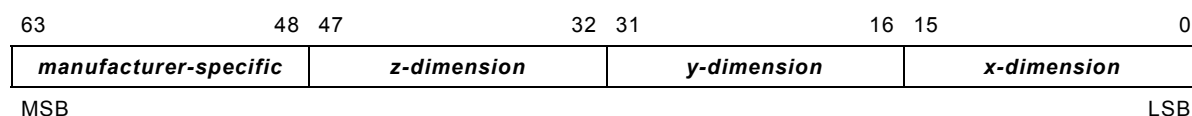

Figure 13 — Structure of the second TPDO

A.5.4 Specific PDO mapping for 3-D joysticks

If the specific functionality field is 02_h, the joystick shall use the first TPDO with the pre-defined mapping as shown in Figure 14.

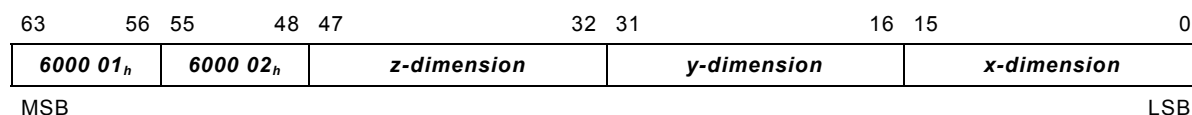

Figure 14 — Structure of the first TPDO

A.5.5 Specific PDO mapping for 2-D joysticks

If the specific functionality field is 03_h, the joystick shall use the first TPDO with the pre-defined mapping as shown in Figure 15.

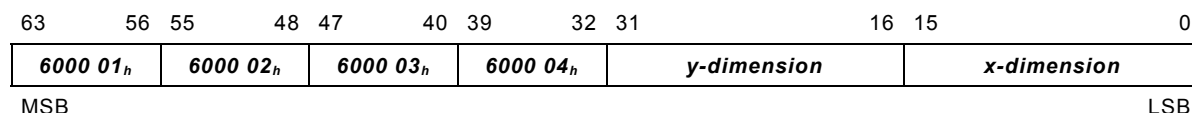

Figure 15 — Structure of the first TPDO

A.6 Joystick signal conditioning

A.6.1 Introduction

The analogue inputs representing the x, y, and z dimension are pre-scaled and offset by using the objects 6432_h (642F_h) respectively 6431_h (642E_h). If a deadband and post-scaling are required, the objects 6460_h (6461_h) respectively 6462_h (6463_h) are used.

A.6.2 Object 6460_h: Analogue input dead-band unsigned

This object shall set the dead-band for the analogue inputs (6401 01_h to 03_h). Figure 16 shows the relationship between the analogue input objects with dead-band-functionality for 16-bit (and 32-bit) access.

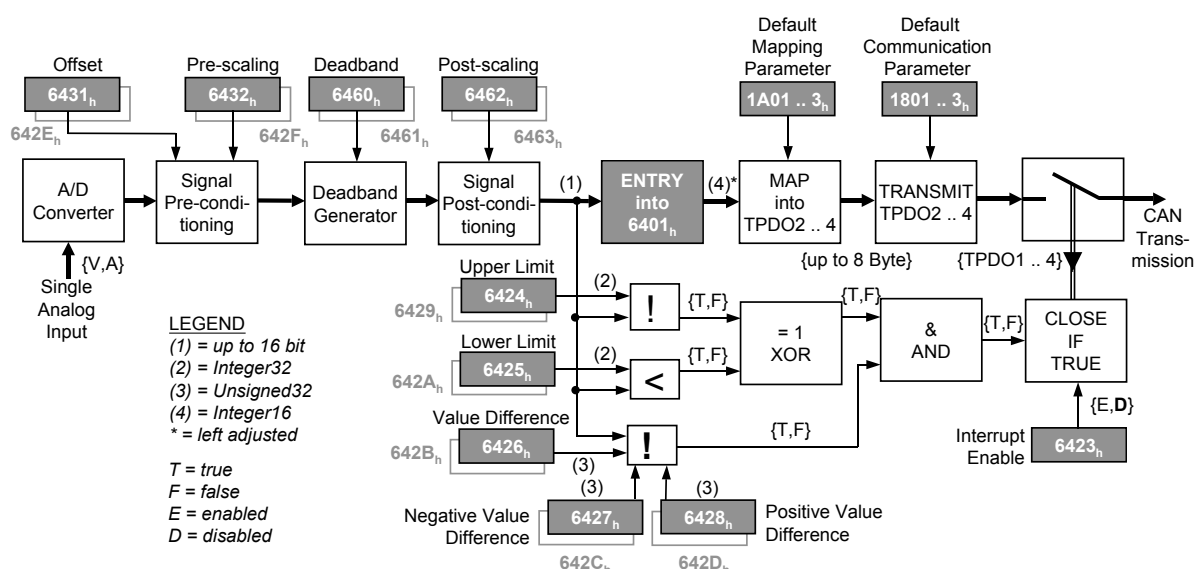

Figure 16 – Analogue Input with dead-band-functionality

Configuration of the analogue input dead-band float object (6461_h) shall cause also value change in the 6460_h object and vice versa.

Table 202 specifies the object description and Table 203 specifies the entry description.

Table 202 — Object description

Attribute	Value
INDEX	6460 _h
Name	Analogue input dead-band unsigned
Object code	Array
Data type	Unsigned32
Category	Optional

Table 203 — Entry description

Attribute	Value
Sub-Index	00 _h
Description	Number of analogue inputs
Access	ro
Entry category	Mandatory
PDO mapping	No
Value range	03 _h
Default value	No
Sub-Index	01 _h
Description	Analogue input 01 _h
Access	rw
Entry category	Mandatory
PDO mapping	Optional
Value range	Unsigned32
Default value	0000 0000 _h
Sub-Index	02 _h
Description	Analogue input 02 _h
Access	rw
Entry category	Mandatory
PDO mapping	Optional
Value range	Unsigned32
Default value	0000 0000 _h
Sub-Index	03 _h
Description	Analogue input 03 _h
Access	rw
Entry category	Mandatory
PDO mapping	Optional
Value range	Unsigned32
Default value	0000 0000 _h

A.6.3 Object 6461_h: Analogue input dead-band float

This object shall set the dead-band for the analogue inputs (6401 01_h to 03_h).

Configuration of the analogue input dead-band unsigned object (6460_h) shall cause also value change in the 6461_h object and vice versa.

Table 204 specifies the object description and Table 205 specifies the entry description.

Table 204 — Object description

Attribute	Value
INDEX	642A _h
Name	Analogue input dead-band float
Object code	Array
Data type	Real32
Category	Optional

Table 205 — Entry description

Attribute	Value
Sub-Index	00 _h
Description	Number analogue inputs
Access	ro
Entry category	Mandatory
PDO mapping	No
Value range	03 _h
Default value	No
Sub-Index	01 _h
Description	Analogue input 01 _h
Access	rw
Entry category	Mandatory
PDO mapping	Optional
Value range	Real32
Default value	0,0
Sub-Index	02 _h
Description	Analogue input 02 _h
Access	rw
Entry category	Mandatory
PDO mapping	Optional
Value range	Real32
Default value	0,0
Sub-Index	03 _h
Description	Analogue input 03 _h
Access	rw
Entry category	Mandatory
PDO mapping	Optional
Value range	Real32
Default value	0,0

A.6.4 Object 6462_h: Analogue input post-scaling unsigned

This object shall set the gain after the addition of dead-band-functionality for the analogue inputs (6401 01_h to 03_h).

Configuration of the analogue input post-scaling float object (6463_h) shall cause also value change in the 6462_h object and vice versa.

Table 202 specifies the object description and Table 203 specifies the entry description.

Table 206 — Object description

Attribute	Value
INDEX	6462 _h
Name	Analogue input post-scaling unsigned
Object code	Array
Data type	Unsigned32
Category	Optional

Table 207 — Entry description

Attribute	Value
Sub-Index	00 _h
Description	Number of analogue inputs
Access	ro
Entry category	Mandatory
PDO mapping	No
Value range	01 _h to 03 _h
Default value	No
Sub-Index	01 _h
Description	Analogue input 01 _h
Access	rw
Entry category	Mandatory
PDO mapping	Optional
Value range	Unsigned32
Default value	0000 0000 _h
Sub-Index	02 _h
Description	Analogue input 02 _h
Access	rw
Entry category	Mandatory
PDO mapping	Optional
Value range	Unsigned32
Default value	0000 0000 _h

Sub-Index	03 _h
Description	Analogue input 03 _h
Access	rw
Entry category	Mandatory
PDO mapping	Optional
Value range	Unsigned32
Default value	0000 0000 _h

A.6.5 Object 6463_h: Analogue input post-scaling float

This object shall set the gain after the addition of dead-band-functionality for the analogue inputs (6401 01_h to 03_h).

Configuration of the analogue input post-scaling unsigned object (6462_h) shall cause also value change in the 6463_h object and vice versa.

Table 208 specifies the object description and Table 209 specifies the entry description.

Table 208 — Object description

Attribute	Value
INDEX	6463 _h
Name	Analogue input post-scaling float
Object code	Array
Data type	Real32
Category	Optional

Table 209 — Entry description

Attribute	Value
Sub-Index	00 _h
Description	Number analogue inputs
Access	ro
Entry category	Mandatory
PDO mapping	No
Value range	01 _h to 03 _h
Default value	No
Sub-Index	01 _h
Description	Analogue input 01 _h
Access	rw
Entry category	Mandatory
PDO mapping	Optional
Value range	Real32
Default value	0,0

Sub-Index	02 _h
Description	Analogue input 02 _h
Access	rw
Entry category	Mandatory
PDO mapping	Optional
Value range	Real32
Default value	0,0
Sub-Index	03 _h
Description	Analogue input 03 _h
Access	rw
Entry category	Mandatory
PDO mapping	Optional
Value range	Real32
Default value	0,0

A.7 Joystick implementation hints

A.7.1 Periodical PDO transmission

If periodical PDO transmission is requested, the event timer is set to $\neq 0$.

A.7.2 Additional proportional inputs

If additional proportional inputs are required, the pre-defined 3rd and 4th TPDO are used.

A.7.3 Transmission of proportional inputs

In order to transmit only the first proportional value different from 0, the analogue input set-up objects are used.